

Modernfold GWS

DRS

Installation Manual

Table of Contents

362SR/362TR, 600SR, 800SR, 1000SR Glass Wall

Introduction	Page 2
Step 1 – Tools Required	Page 3
Step 2 – Preliminary Installation Instructions #17G Direct Mount #17G Bracket Mount Drop Ceiling Support Installation G150 Direct Mount G150 Bracket Mount Installing Switches Leveling Track	Page 3 - 12
Step 3 – BTS Closer Installation	Page 13
Step 4 – 8852 Pivot Installation	Page 14
Step 5 – Panel Installation Instructions Pivot Panel Intermediate Panel Leveling and Floor Strike Installation Pivot Panel Hardware Installation BTS Closer Adjustments	Page 14 - 31
Step 6 – Operation Extending Panels – Setting IFB Stacking Panels	Page 32 - 35
Step 7 – Maintenance	Page 36
Step 8 – Reference Details #17G Header G150 Header	Page 37 - 38
Step 9 – Reference Page	Page 39
Step 10 – Hardware Items	Page 40 - 45

PROCEDURE FOR INSTALLING GLASS WALL

Purpose

To properly document the correct methods and processes required for the installation of Glass Wall.

Before Beginning Installation

Review drawing and field Conditions

- Make sure you have drawings for fabrication, not approval drawings.
 - Verify opening dimensions against drawings.
 - Examine pocket and/or stack area for proper clearance and adequate depth.
 - Look for any job site conditions that could interfere with installation or operation of the partition.
-
- **All discrepancies must be corrected before installation can begin**
 - **Read installation instructions completely**
 - **Call the Modernfold Tech Line if you have problems or questions with installation at 1-866-561-8324**
 - **Verify all parts against the packing list**
 - **Locate and lay out all pieces**
 - **Be prepared to verify track level and straightness with laser or other leveling instruments. Finished track installation must be straight and level.**

Step 1: Tools Required

- Hammer Drill with ¼", ½", ¾", and 1" bits
(Chisel points if BTS closer to be installed)
- 3/16" Allen wrench (top pivot, door closure block #17G)
- 6mm Allen wrench (top pivot, door closure block G150)
- 5/16" Allen wrench (top pivot, retainer plate #17G & G150)
- 5mm Allen wrench (top pivot, adj. roller block #17G & G150)
- 18mm open end wrench (top pivot, adj. roller block nut #17G)
- 17mm open end wrench (top pivot, adj. roller block nut G150)
- 1" open end wrench (trolley adjustment)
- ¾" open end wrench (jamb nut)
- Spanner wrench (pivot panel hardware)
- 2" masking tape and chalk line
- Drill
- ¼" plastic plug anchors – 2 per floor strike
- Blade knife

Step 2: Preliminary Installation Instructions

Modernfold defines the **preliminary installation** as the installation of the suspension system and its related parts. The Glass Wall can be installed on our #17G and G150 suspension systems. The installation of each of these systems is essentially the same: each piece of track is mounted to the header, secured together, leveled and plumbed.

Special Note:

To ease the installation process and reduce the number of possible errors, it may help to place the pieces of the suspension system on the floor in their proper positions, if possible, according to the layout drawings. This is especially useful if you are installing a switch & curve or programmed intersection layout.

Opening Tolerances and Sight Guidelines

Steel - Must be level within .13" across the entire length of the track including the stack area.

Track – Must be level within .13" across the entire length of the track including the stack area. Track installation must be laser checked for an accurate straight rundown the length of the opening. NOTE: Direct mounted track must be shimmed level within .13".

Floor – Must be level within .13" across the entire length of the opening including the stack area. The maximum out of level, overall, is .25" on either side of the opening.

Beginning the Installation - #17G Direct Mount

Chalk a line in the center of the header where the track will hang. Mark the spacing of each thru hole in the track along this center line. The track is pre-drilled every 6" with a 5/32" clearance hole for the screws. Then drill (or tap) the header for the proper type of fastener. The standard fastener shipped with the suspension system is a #14 round head wood screw, 2-1/2" long. If you are mounting the track to another surface, such as concrete or steel, then you will have to provide the proper anchor for your situation.

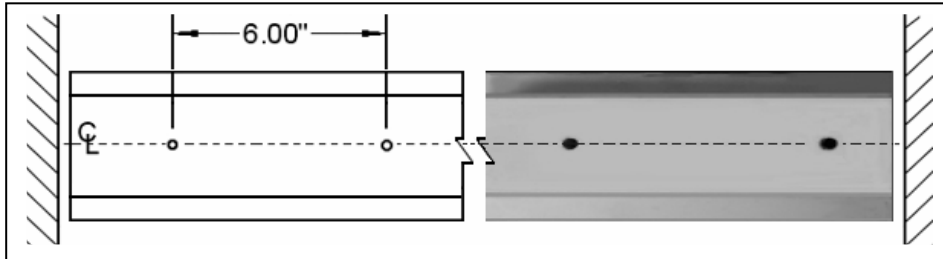

Figure 1: Hole spacing for direct mounting #17G track

Attach Track to Header

Starting with the first section of track, at the *stack* end of the opening, secure each section to the header. Be sure each section is aligned with and butted tightly to the previous one and that there are no burrs or sharp edges upon which the carrier can catch. The track must be level within 1/8" across the opening width. Pay particular attention to mounting the screws completely into the header, so that each screw is driven as far in as possible. The screw head can interfere with the operation of the trolley if it isn't completely secured.

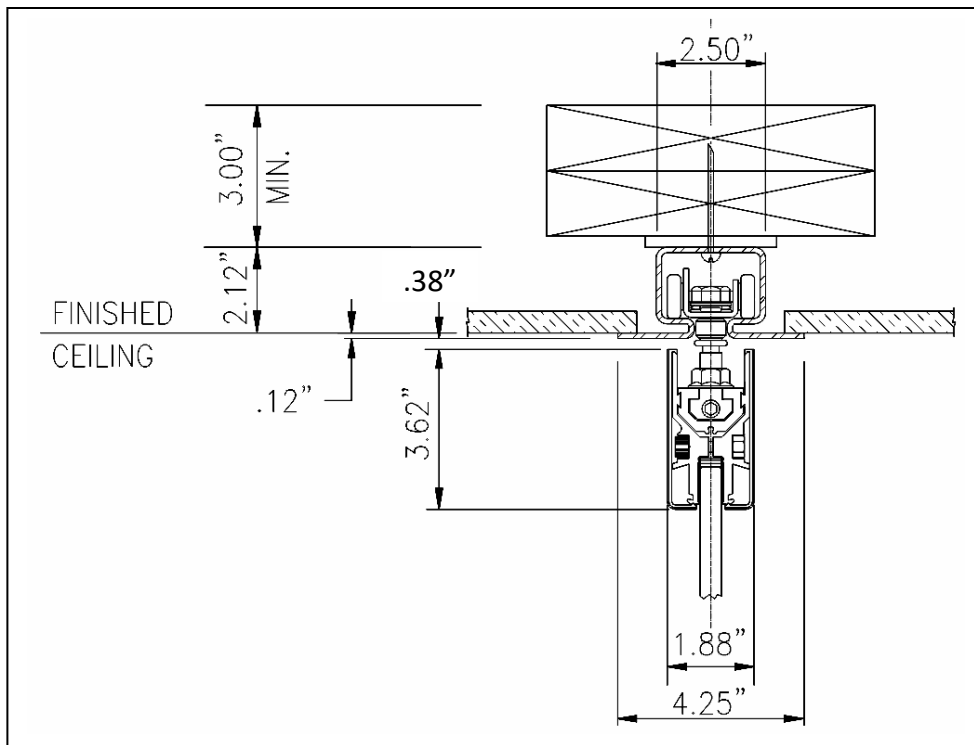

Figure 2

Joining the Track Sections

Direct mounted #17G track sections are joined with splice tabs at each joint. (However, do not insert a tab at the 4'-0" removable section until the installation is complete.) *Be sure that the sections are properly aligned, with no protruding edges.* If you cut any track sections to fit in the field, you must bevel the edges where the cuts were made. This will help assure a smooth transition and appearance at each joint.

Once the sections are in place, drive a splice tab into the slot formed by the bottom of the track shape. If the splice tab does not fit securely, remove it and bend each end slightly downward, until the tab fits securely in the track.

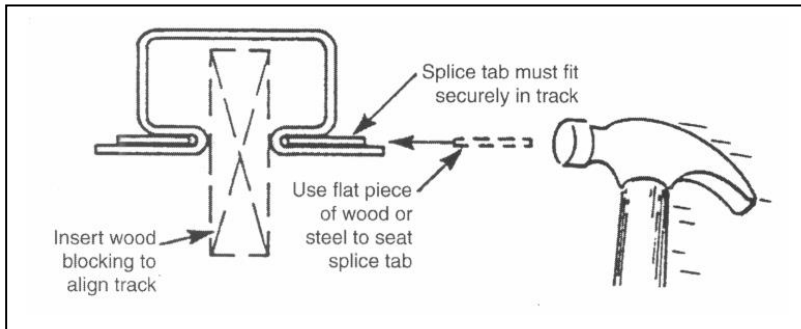

Figure 3: Inserting splice tab into track joint

Beginning the Installation - #17G Bracket Mount

Special Note: Most stack configuration weldments are pre-drilled for their respective hanger brackets. Because these sections support the weight of the entire partition in a small area, the mounting holes are located closer together. Refer to the *Hanger Rod Layout* drawing for proper spacing. The track is hung from the structural support by the hanger rods with a thru hole connection at the track bracket.

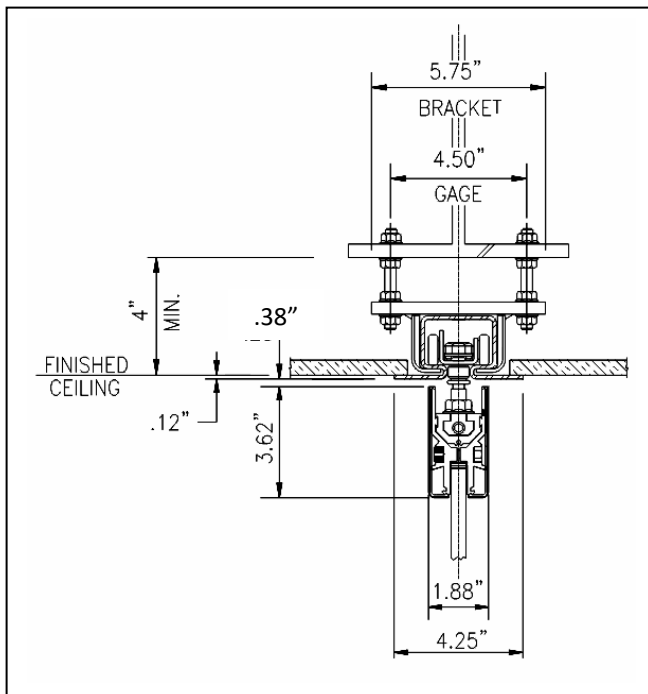

Figure 4: #17G Track and Header Detail

Installing the Hanger Rods

Attach the first two (2) pairs of hanger rods to the structural support using a 3/8"-16 flange nut on *both* sides of the support. Then attach a pair of hanger rods at or near the *lead* end of the first section of track. This procedure will allow you to hang each end of the track section, and then install the remaining intermediate hanger rods. Alternatively, you can install all of the hanger rod pairs at the same time. All track fabrication height adjustments can be made at the track, or at the Structural support, if possible. This will allow you to attach the brackets sequentially, which may be easier for some job site conditions.

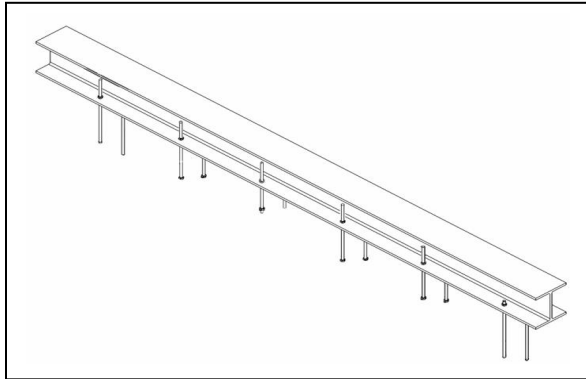

Figure 5: Installing Hanger Rods

Attaching the Hanger Brackets

Starting at the stack end, slide the required number of brackets (from the *Hanger Rod Layout* drawing) onto the track. You will need to adjust each bracket's position as the sections of track are hung.

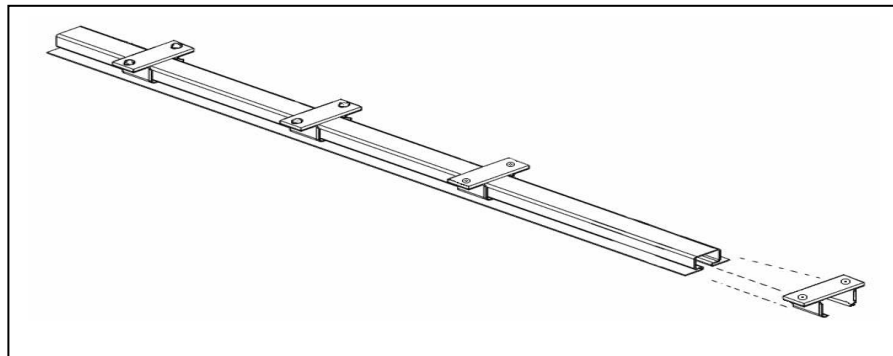

Figure 6: #17G Hanger Bracket Installation

Installing Switches

#17G

The #17G switch installs much the same as the track itself: mounted with brackets and attached to hanger rods, or directly to the header. Be sure to check the layout drawings for the proper position and orientation of the switch and curve intersections in your installation. It is important that each switch be installed in its proper place in order for the switch's programming lugs to perform appropriately.

Special Note: You must use a #17G Glass Wall switch for a #17G Glass Wall installation to utilize the Glass Wall #17G trolley with the Delrin (nylon) tire. If you are using a standard #17 switch you must use standard steel wheeled trolleys.

Hanging Track Sections

First Section

Lift the track into place and slide the brackets over the hanger rods, either at each end or sequentially, depending upon which method of hanger rod installation you used. Again, be sure to use a flange nut on **both** sides of the hanger bracket. Do not completely tighten the flange nuts at this time. You will be adjusting them as each track section is installed.

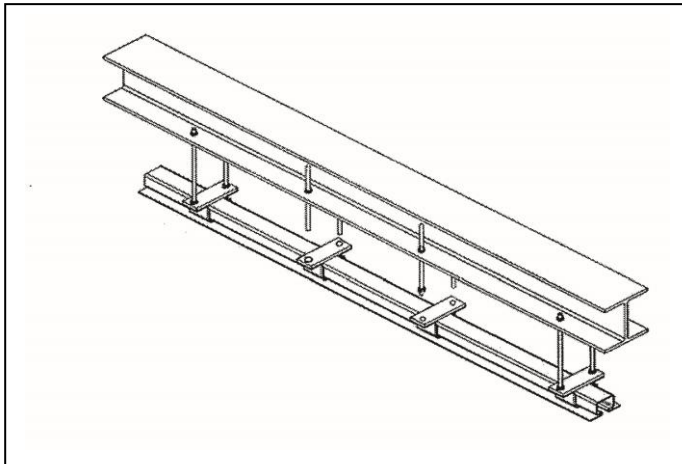

Figure 7: Installing First Track Section

Intermediate Sections

Each track section is hung in the same manner as the first section. Attach a pair of hanger rods near each end of the section (or for each bracket), securing to the structural support with a flange nut on both sides. (If the attachment at the structure is not a thru-hole connection, only one flange nut is required).

Final Section

The final (removable) track section is also hung by attaching the hanger rods to the structural support and to the brackets on the track. However, when using the #17G suspension systems, the track itself can be removed from the brackets to allow for the panel installation.

Joining Track Sections

#17G track sections are joined with splice tabs at each intersection. Bracket mount splicing is identical to direct mount.

Installing Track Stops, #17G & G150

Figure 9: Typical Track Stop Locations: Track stops should be installed at all of the dead ends of the track. The purpose is to protect the glass edges from being damaged by inadvertent contact with the fixed walls. With that in mind each stop should be individually set to the glass edge it is going to protect. Both types of stops, #17G & G150, can be locked down through the gap in the track, however they need to be installed in their relative position prior to installing the trolleys, or temporarily positioned while installing the track.

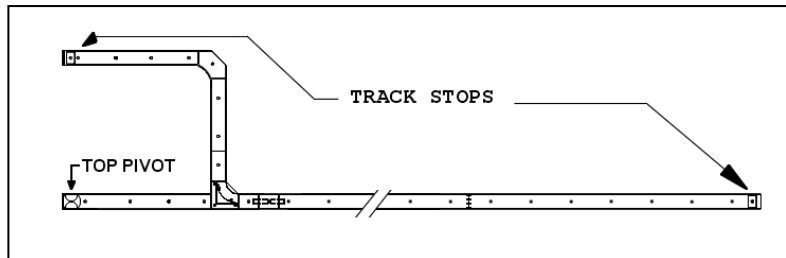
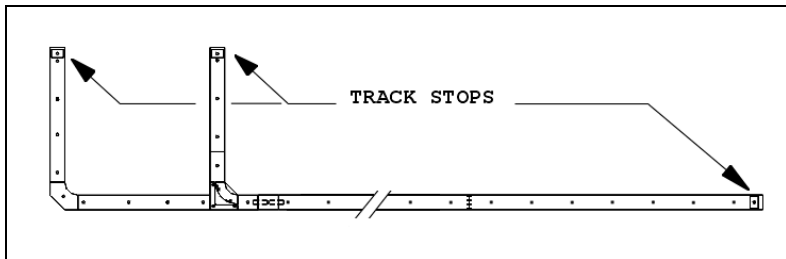

Figures 8: Typical Track Stop Locations

Drop Header Trim Installation

To fill the gap in the opposite side of the track, you need to insert the drop ceiling support and spring clip between the top of the track flange and the ceiling. Insert the spring clip into the track above the flange and push firmly until it snaps into place. Then insert the drop ceiling support and push it in firmly, until it is captured by the spring clip.

NOTE: It is especially important to utilize Drop Ceiling Support strips with *regular* ceiling tile.

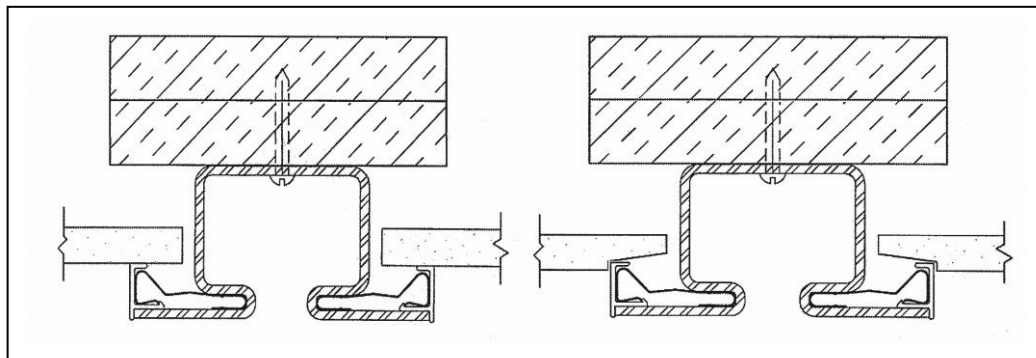

Figure 9: Installing Dropped Ceiling Support Clips & Trim with different styles of tile

Beginning the Installation – G150 Direct Mount

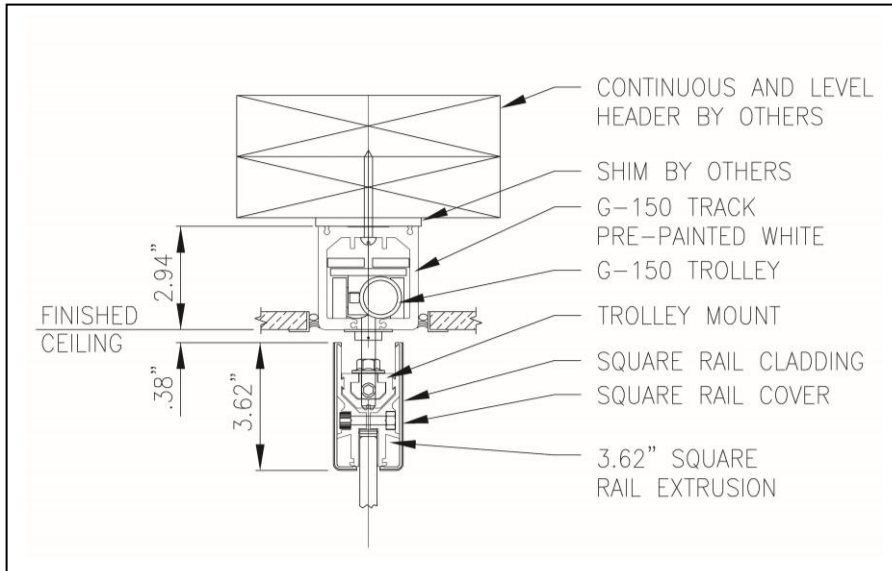

Figure 10: Surface Mounted Installation

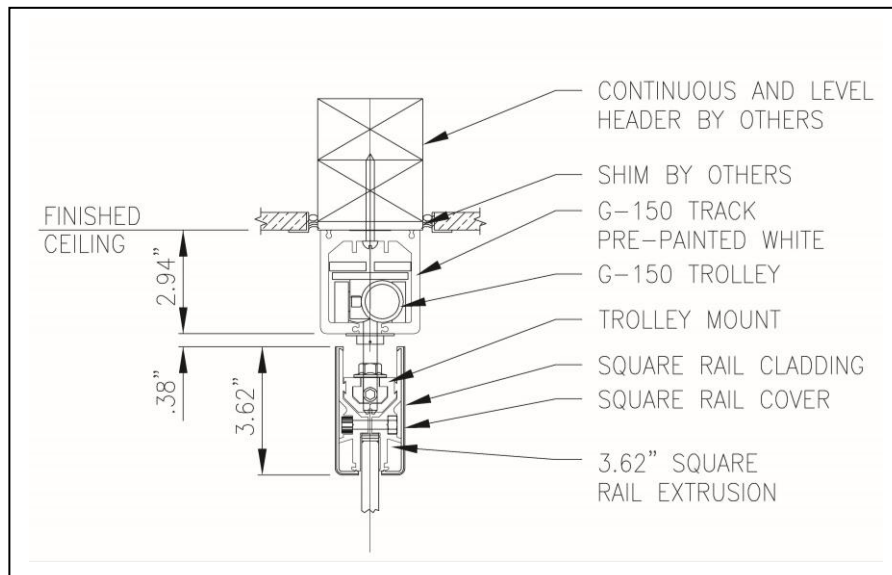

Figure 11: Recess Mounted Installation

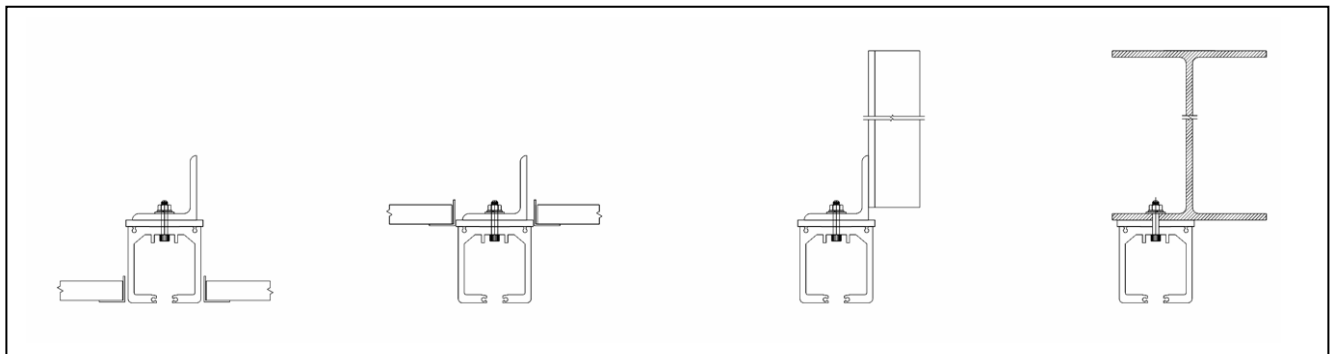

Figure 12: Possible Installations

Opening Tolerances and Sight Guidelines

Steel - Must be level within .13" across the entire length of the track including the stack area.

Track – Must be level within .13" across the entire length of the track including the stack area. Track installation must be laser checked for an accurate straight rundown the length of the opening. NOTE: Direct mounted track must be shimmed level within .13".

Floor – Must be level within .13" across the entire length of the opening including the stack area. The maximum out of level, overall, is .25" on either side of the opening.

G150 Direct Mount

Chalk a line in the center of the header where the track will hang. Mark the spacing of each thru hole in the track along this center line. The track is pre-drilled every 12" with a 5/16" clearance hole for the screws. Drill (or tap) the header for the proper type of fastener. There are no fasteners shipped with the suspension system. You will have to provide the proper anchor and fastener for your type of installation.

Ceiling Substructure for Track rail and Installation of the Track rail

The track rail must be bolted over its entire length (including the stacking track area) to a correctly aligned horizontal (longitudinally and transversely) ceiling structure. The substructure should be designed to accommodate the total weight of all the panels both in the stacking area and in the partition section.

Hanging Track Sections

The first assembly to be installed will be the stack area weldment. Lift into place and install with fasteners determined by type of header system installed. Next section (piece to install is the 3.94" removable maintenance) section. Groove pins will be used at the running edge joints only. Drill, drill/tap header to accommodate same fastener used to attach other track sections. Screw removable section to header making sure aligner plate fits properly then use a blade screwdriver to position pins over joints **after** the panels have been installed!

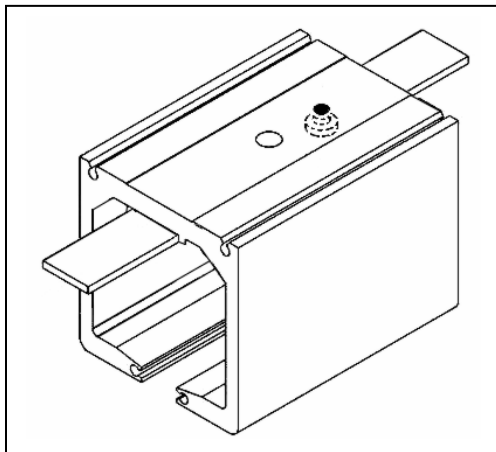

Figures 13: Removable (Maintenance) Track Section

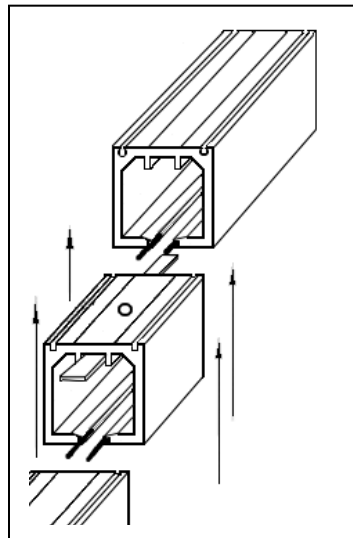

Continue installing the remainder of the intermediate sections. First by guiding track section on to previous section's splice pins then fastening to the header. Lastly, install 4 groove pins into the opposite end of the track, groove end first inserts approximately 3/8" with 3/8" exposed. Continue with remainder of sections until complete.

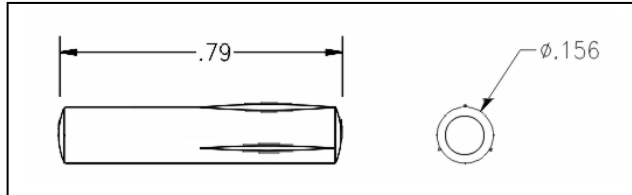

Figure 14: Groove (splice) Pin

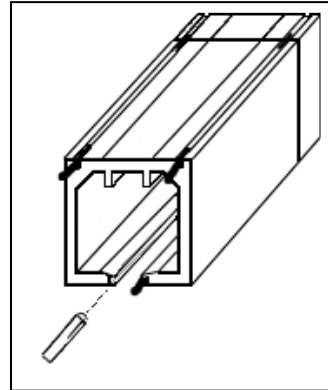

Figure 15: Installing Groove Pins in Track Section

Installing Switches

#17G and G150

The #17G switch installs much the same as the track itself: mounted with brackets and attached to hanger rods, or directly to the header. The G150 switch is similar to the #17G with respects to the weight and the size. Be sure to check the layout drawings for the proper position and orientation of the switch and curve intersections in your installation. It is important that each switch be installed in its proper place in order for the switch's programming lugs to perform appropriately.

Special Note: You must use a #17G Glass Wall switch for a #17G Glass Wall installation to utilize the Glass Wall #17G trolley with the Delrin (nylon) tire. If you are using a standard #17 switch you must use standard steel wheeled trolleys.

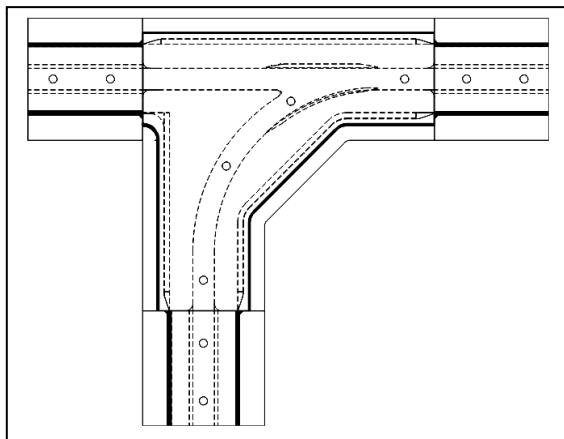

Figure 16: #17G Direct Mount L.H. Switch

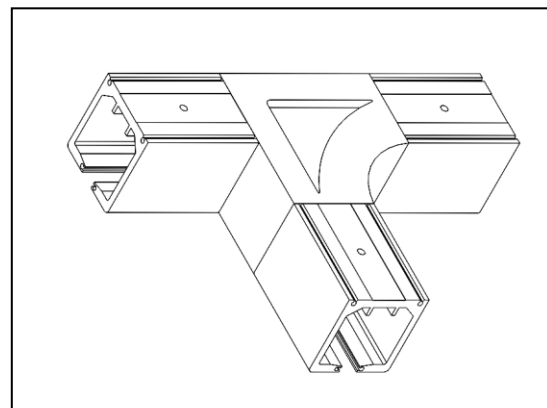

Figure 17: G150 Direct Mount L.H. Switch

Leveling the Track

When all of the track sections are installed, level the entire track. Be sure fabrication height is correct, then check for any loose hanger rod flange nuts. If the track is direct mounted, shim the entire track as necessary to correct any discrepancies in the header. Finally, check the track joints to make sure the track is straight and that all of the sections fit together without gaps. Also make sure that there are no burrs or offsets to interfere with trolley operation. Tighten all of the bolts on the splice cover assemblies or, for direct mounted track, make sure that the splice tabs or splice pins are positioned securely.

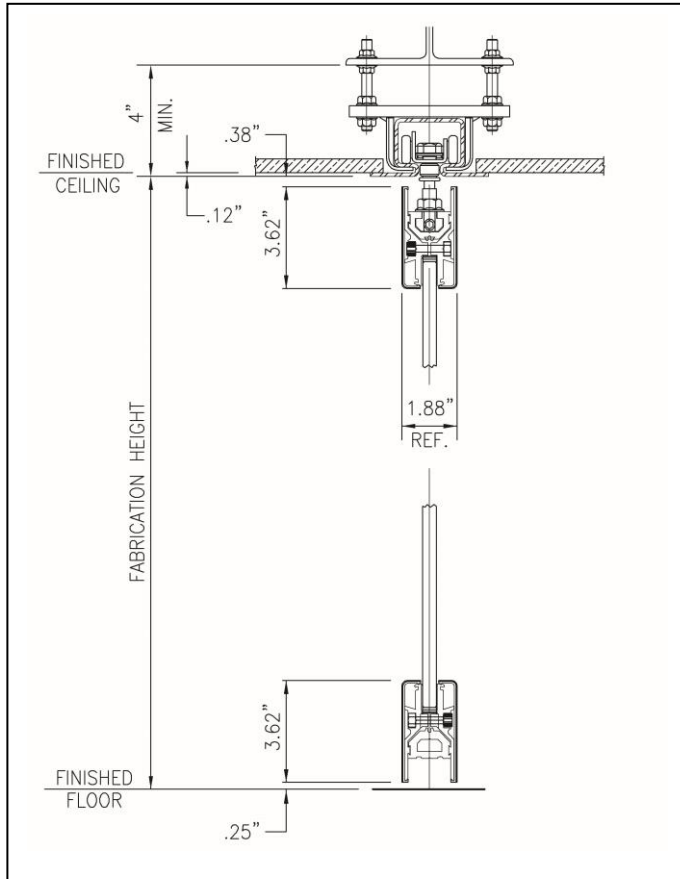

Figure 18

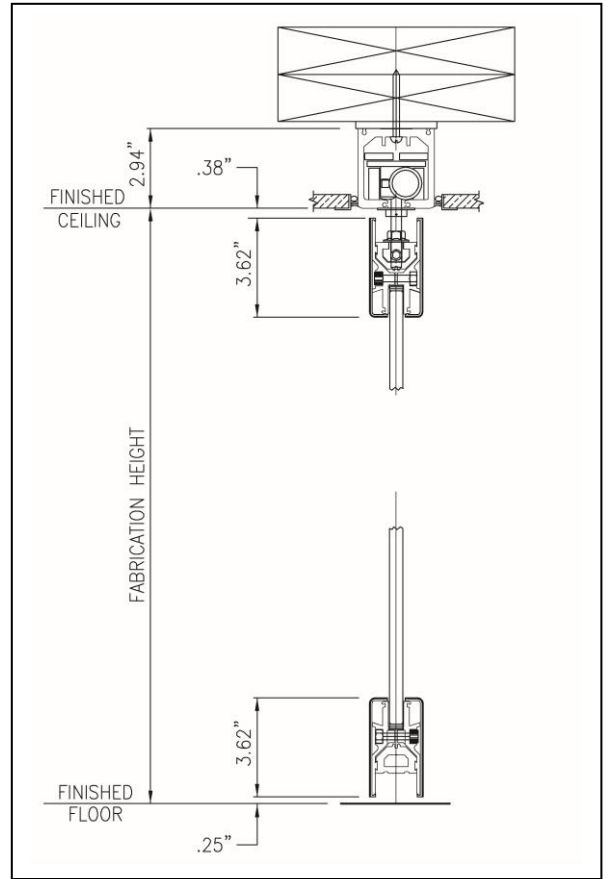

Figure 19

Cleaning and Lubricating the Track

Clean the inside of the track to remove dirt, shavings or other foreign matter that may interfere with the operation of the partition. (Small screws can be particularly damaging to the trolley tires.) Then coat the inside of the track with a thin covering of petroleum jelly (i.e., Vaseline).

Step 3: BTS Closer Installation

The best time to install the closer is during the track preliminary installation before the floor finishing is complete. The BTS 80 Closer ships with an additional collar mounted around the perimeter of the mounting box. This is only used if you are installing a Convertible Panel. For standard PC1 applications it must be removed. Mark location of center pivot according to custom layout drawings.

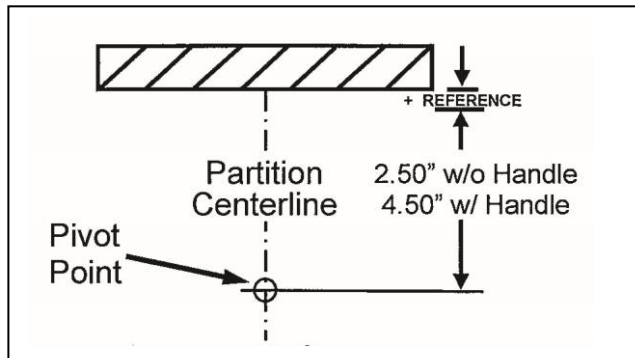

Figure 20: Locating pivot point.

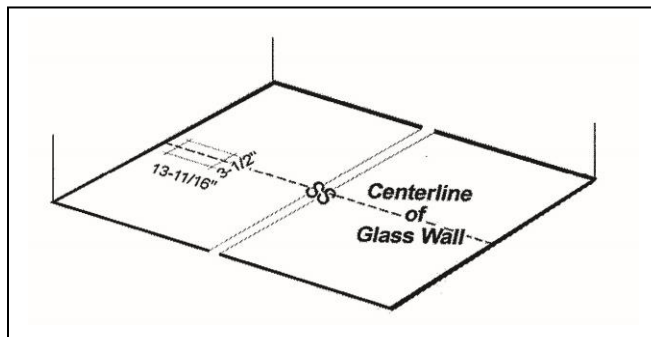

Figure 21: Layout for BTS cutout

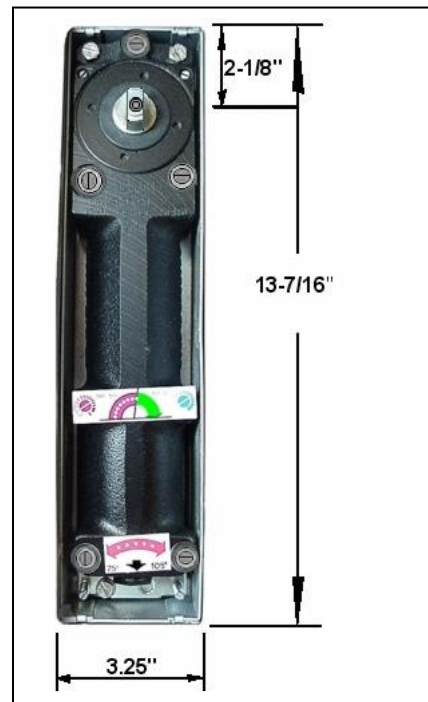

Figure 22: BTS 80 Door Closer

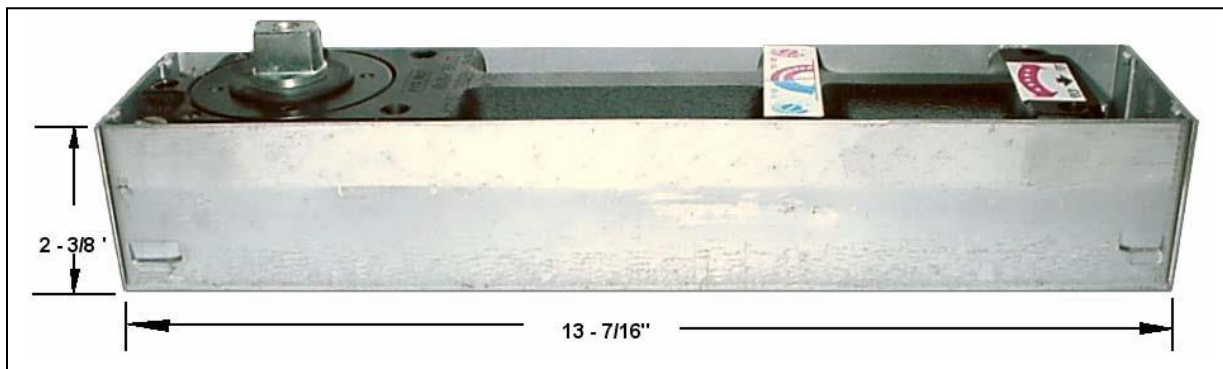

Figure 23: Box dimensions

Layout the dimensions of the BTS Closer on the floor. Mark dimensions of BTS closer $\frac{1}{4}$ " wider than actual dimension of closer box. Cut/chip out concrete to the required depth and width. Place the BTS Closer in the hole, align and grout in place. Set the height of box level with the concrete. The Closer sets level with carpet height. Minor height, level and side-to-side dimension can be made, if necessary, after box is grouted in. Attach cover plate and check level, adjust as necessary.

Step 4: 8852 Pivot Installation

The layout for the bottom pivot assembly is the same as above, locate your pivot point based upon panel being fitted with handles or not, add reference dimension per the layout drawing and attach to the floor. This type of pivot doesn't require a recess. The type of flooring material will determine the proper fasteners to use. The pivot is vertically adjustable, utilize the furnished wrench for adjustments

Special Note: If your installation calls for a mechanical closure, you must install the closure **before installing the panels**. Then proceed to the panel installation instructions.

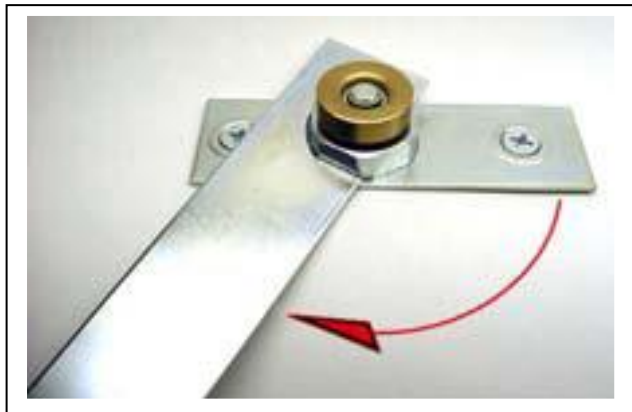
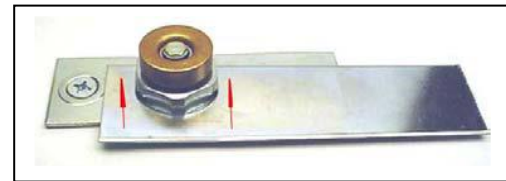
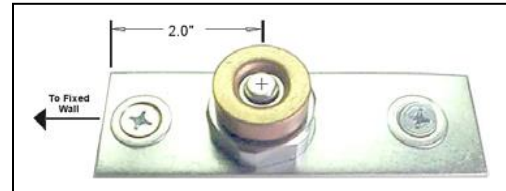

Figures 24

Step 5: Panel Installation Instructions

Before Beginning Installation

If the suspension system was installed at an earlier date, it should be checked for level and readjusted as necessary before panels are installed. Also confirm that all hardware has been properly tightened. Prior to hanging the panels, conduct the following inspections: · Inspect each panel for damage; make any required repairs. · Inspect trolley for damage. Identify each panel and stage in preparation for hanging. (All panels are numbered from the stack end to the lead end). In order to insert the trolleys into the G150 track, you must remove the 3.94" maintenance section of track. #17G Track has a 4'-0" removable section.

NOTE: You must use #17G trolleys (delrin tire) with #17G Switch & Curves. #17G Trolleys *will not* work with standard #17G switch & curves.

Installing the Panels on a #17G Header

If you are installing a partition with a switch & curve or programmed intersection, be sure that each trolley diverter is oriented properly before installing the panels in the track. The location of the diverter is dependent upon the type of stack configuration.

Positioning the Trolley Diverters

If you have a *parallel side stack* configuration, the diverter on the *lead* Trolley of each panel will be on the *same* side as the stack. If the layout calls for a *90° side stack*, the diverter on the *lead* trolley of each panel will be on the *opposite* side as the stack configuration.

Figure 25: #17G Trolley with Delrin wheels

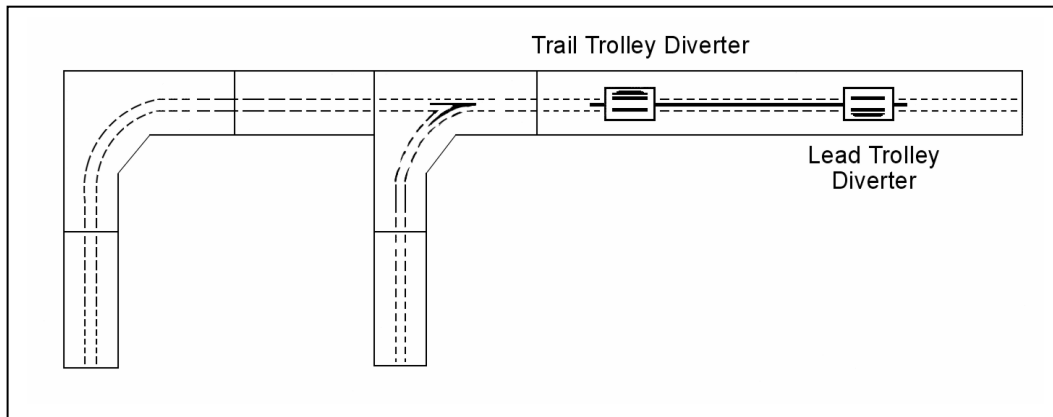
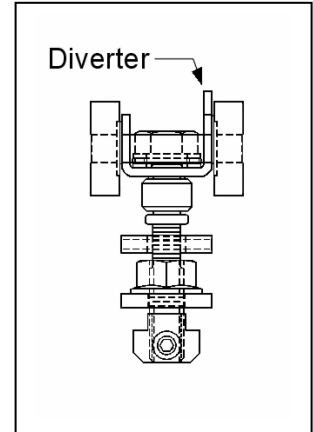

Figure 26: Positioning Diverter for Parallel side stack

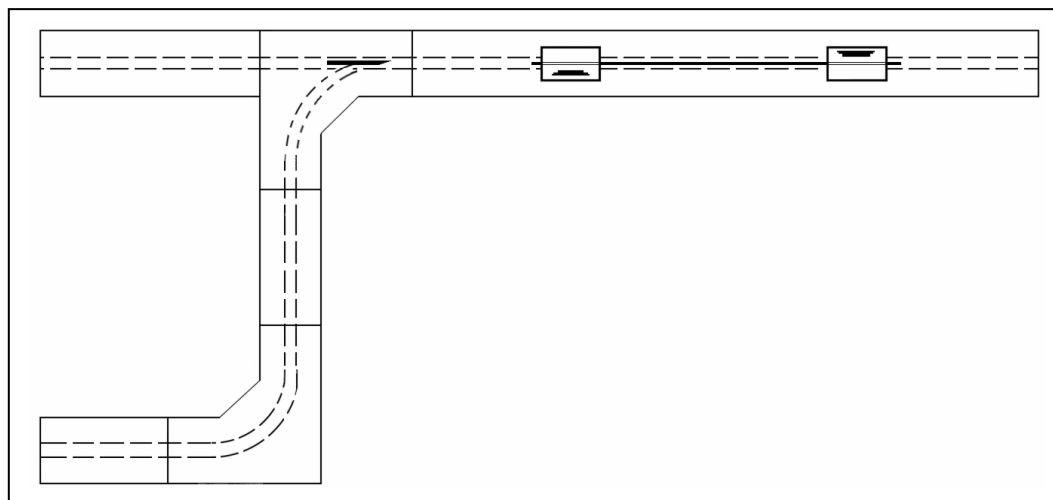

Figure 27: Positioning Diverter for 90-degree side stack

Panel Installation #17G track

Plumb down from centerline of track at both ends and mark at floor (mark on masking tape if carpet). Run a strip of 2" wide masking tape the entire length of the opening and snap a chalk line between centerline marks. (This will keep all floor bolt receivers and strikes in a straight line when installing).

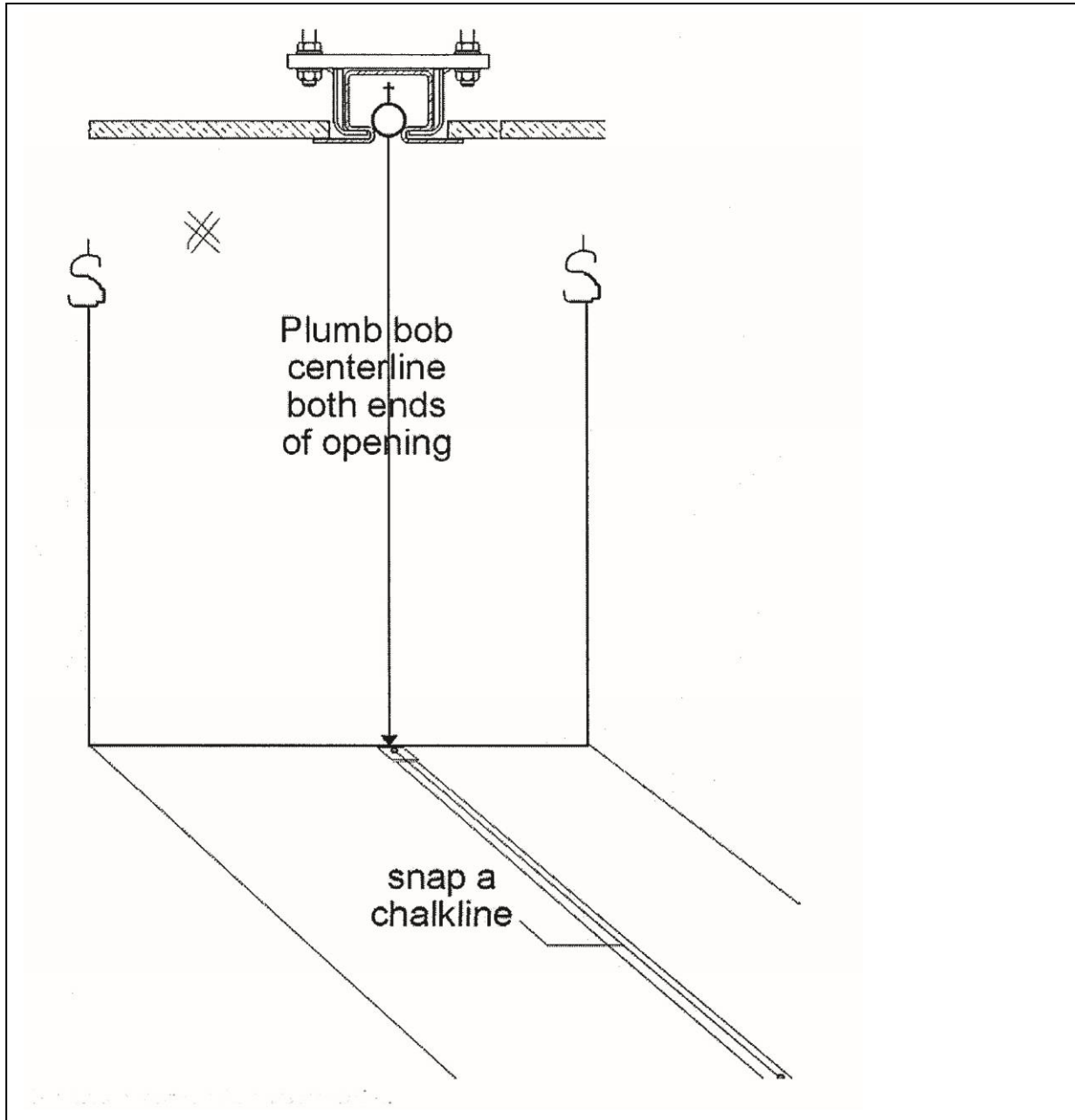

Figure 28: Determining centerline for strike installation.

**Installing Pivot Panel with
BTS 80 Closer**

Put top pivot block in the track and push down to approximately 4' off wall ("A"). Make a mark at track that is plumb up from BTS spindle (locations "B"). Place the bottom of panel parallel to the centerline at approximate location of BTS closer. Stand panel up to approximately 70°-80°, making sure that pivot hole is engaged with BTS spindle. Rotate panel 90° to perpendicular with track as if in stack position, maintaining 70°-80° lean. Slowly raise panel up, feeding pivot pin into pivot block. Move pivot block to pre-marked location and secure – check panel for vertical level and correct gap between trail glass edge and wall. There are two sizes of hex allen wrench required to install the pivot block a 3/16" used on the two screws that lock against the track and a 5/16" wrench is used on the cap screw that locks the retainer plate in place.

SPECIAL NOTE: Place pivot block in approximate install location *prior* to placing trolleys in track, or during installation of preliminary.

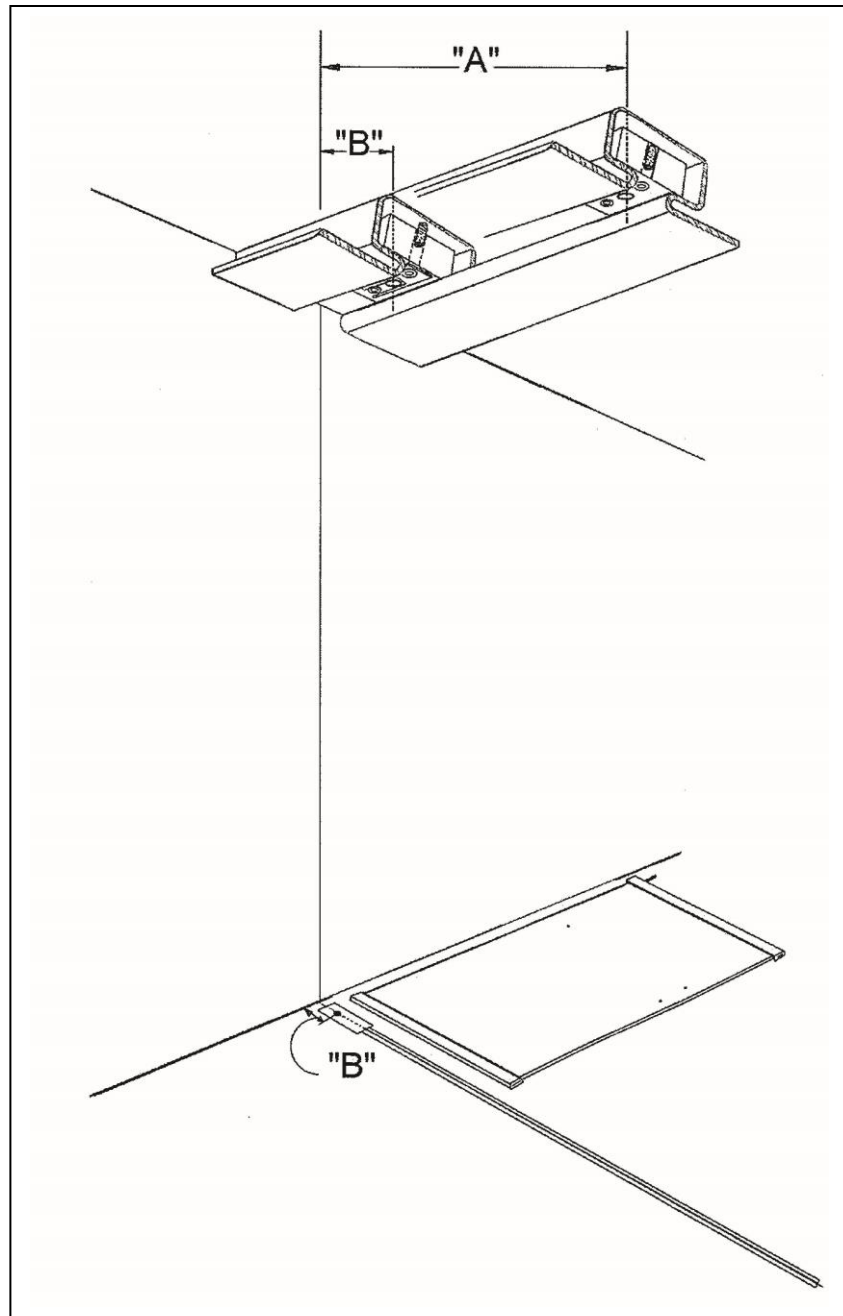

Figure 29: Positioning pivot block and closure panel

Top Pivot Installation

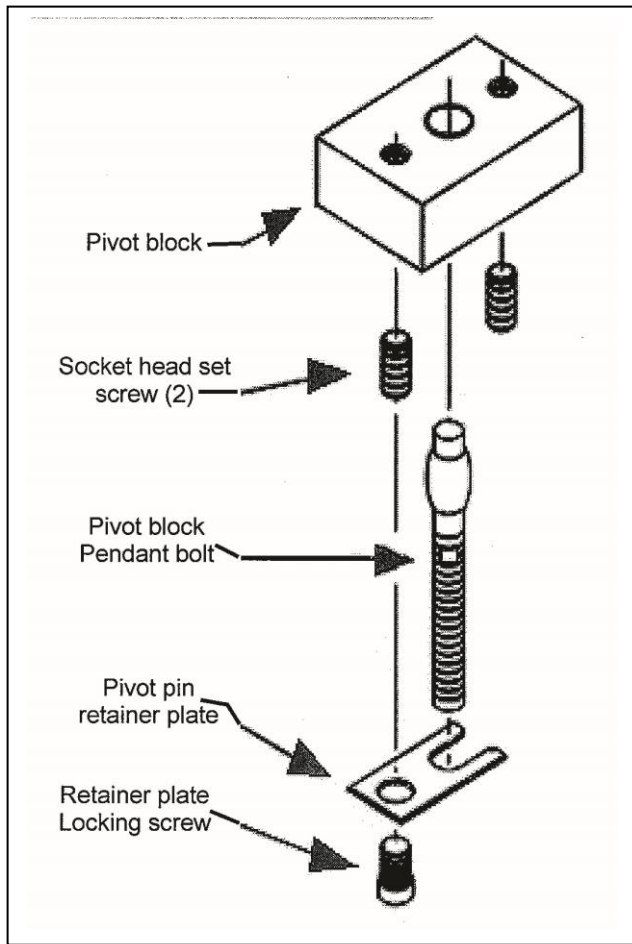

Figure 31

To correctly locate the top and bottom pivots, it is important to obtain the "Shop Drawings" that are job specific for the particular installation that you are working on at this time. For the standard Pivot Closure panel, you will use either 2.5" (**NO** Door Pulls) or 4.5" (**W/** Door Pull or Push Bar) PLUS (+) the reference dimension that is shown on the shop drawings.

Circle Detail 1

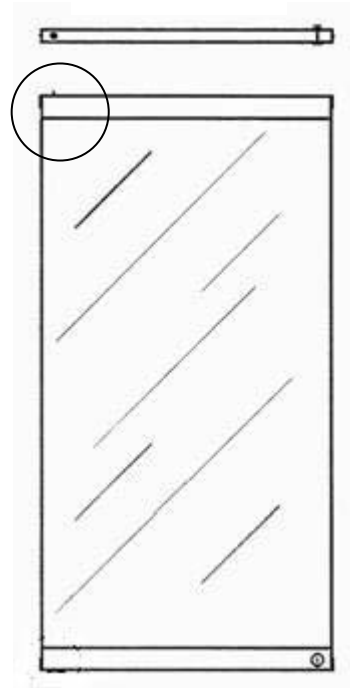

Figure 30

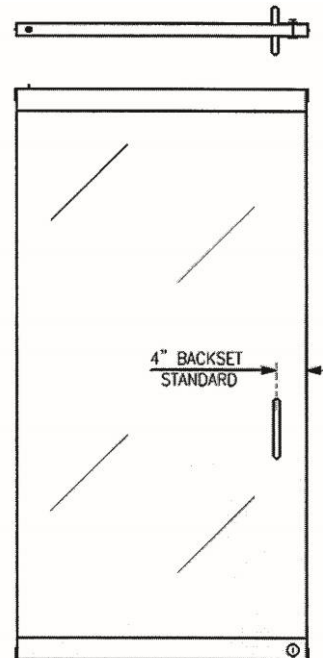

Figure 32

Bottom Pivot Installation

Circle Detail 2

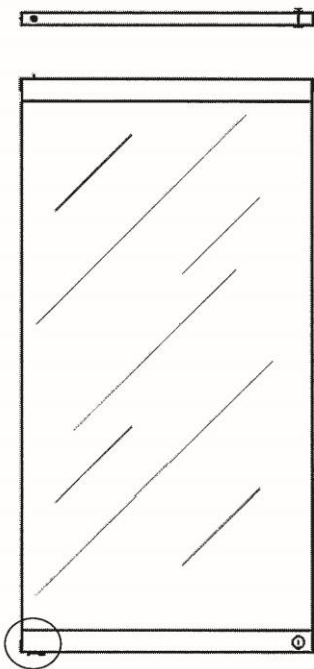
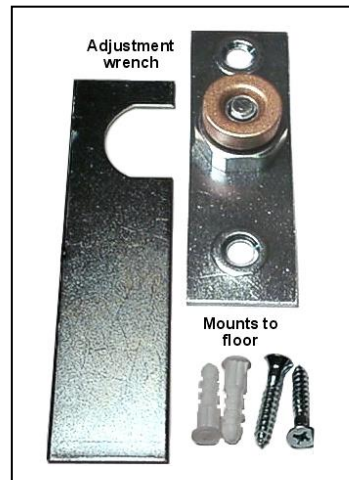

Figure 33



Panel From Circle Detail 2

Figure 34



Floor Mounts from Circle Detail 2

Figure 35

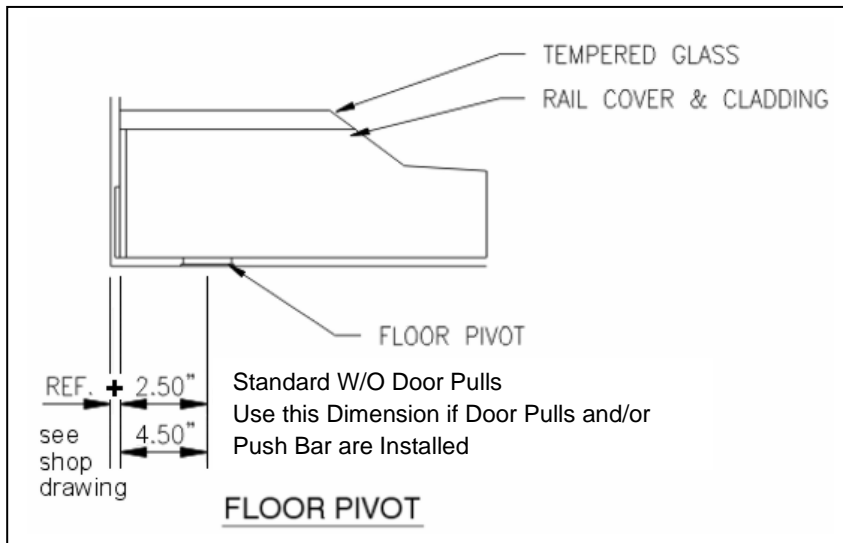

Figure 36

Installing Intermediate Panels

The BTS closer will hold #1 panel in closed position. Install the floor strike to hold open in stacked position or temporarily block in that position. Install each intermediate panel. Trolley removal is not necessary for #17G track. Work panel up slowly keeping trolleys in removable track section gap after panel is straight up, feed trolleys into track, making sure trolley diverters are correctly aligned for proper stacking diverting. After all Intermediate panels are installed, replace the removable track section. Swing intermediate panels out of stack into opening. As each panel is brought into place, offset it out to the side approximately 1" to miss the interconnecting floor bolt, but make contact with the next panel at the rails.

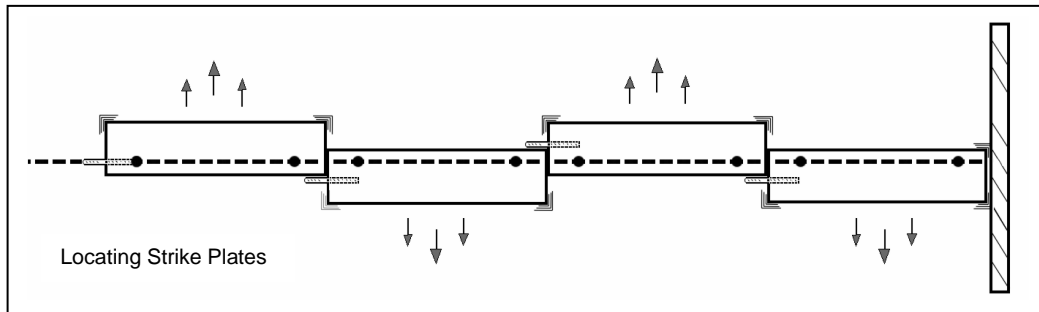

Figure 37

This alignment will let you check for the correct gaps between panel edges and the lead edge to the wall. This needs to be checked before any of the floor strikes are *drilled*. If all the gaps are acceptable dimensionally, proceed with leveling and floor strike installation.

Recommended Gaps

Lead panel, edge at the wall = ref. dimension on shop drawing (3/8" typ.).

Pivot panel, # 2 and the intermediates. = 1/4"

Trail panel (if not equipped with closer or pivot) edge at the wall = reference dimension on shop drawing (3/8" typ.).

Leveling Panels/ Install Floor Strike(s)

Starting with lead panel, check for vertical level. Adjust trolleys as needed by loosening jamb nut (see below) and adjusting trolley height with 1" wrench on flat sides of Nylon Retaining Ring. Ideal top spacing is 3/8" from top of rail to bottom of track.

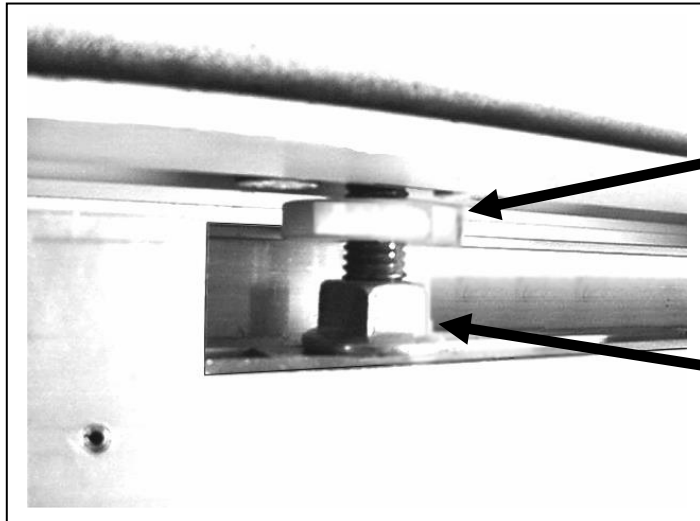

#17G Trolley Adjustment Keeper Use 1" Wrench

#17G Trolley Lock Flange Nut Use 18mm Wrench

Figure 38: leveling panel with #17G track

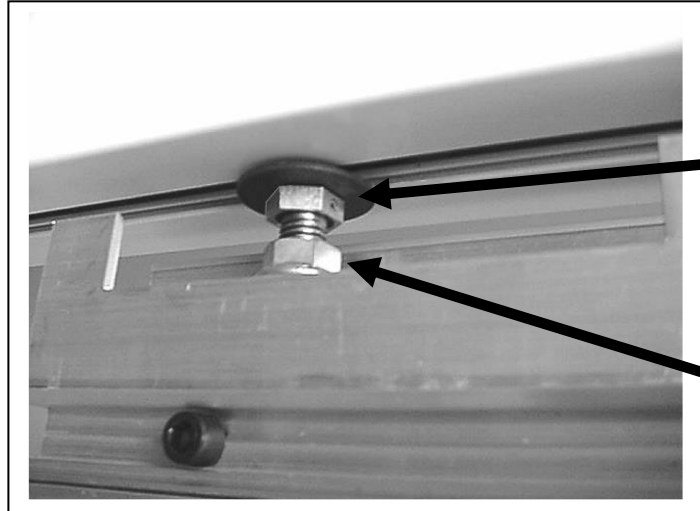

G150 Trolley Adjustment Keeper Use 17mm Wrench

G150 Trolley Lock Flange Nut Use 17mm Wrench

Figure 39: leveling panel with G150 track

Install floor strikes as each panel is leveled. To help mark an accurate location, actuate the floor strike to the floor level. It will make an indentation in the masking tape on the floor. Unscrew floor strike socket from base and use base as a marking template. On carpet, cut the carpet out 1/8" inside of the template lines (see fig 37). This will allow the floor strike to recess flush with the carpet.

Strike Location and Installation Details

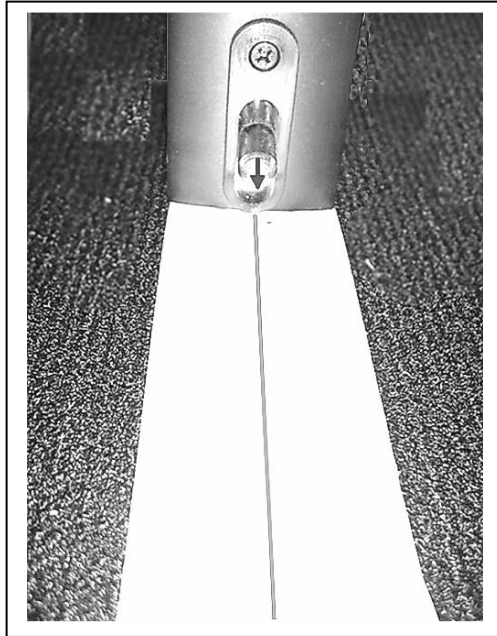

Figure 40: Locating Strike on Centerline

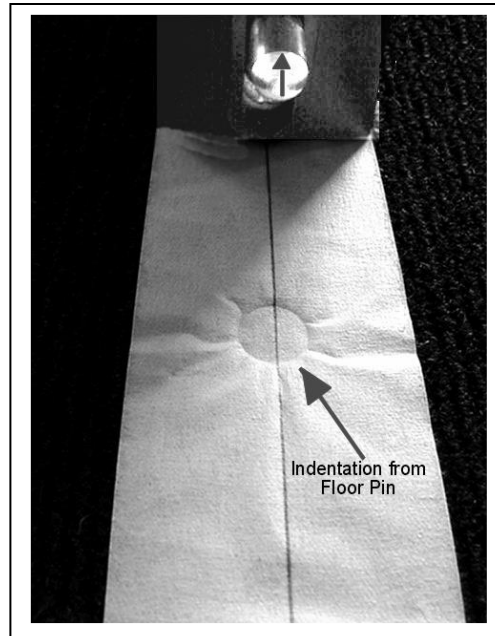

Figure 41: Strike Indentation

Drill (2) 1/4" holes for the mounting screws and a 1" hole for floor strike socket (start with 1/4" pilot hole and increase in 1/4" increments to 1"). Replace dustproof strike socket in strike plate and install mounting screws. Generally speaking, there is some play in the floor strike. The panel may drift away from the centerline slightly. Use the next successive panel strike to position correctly.

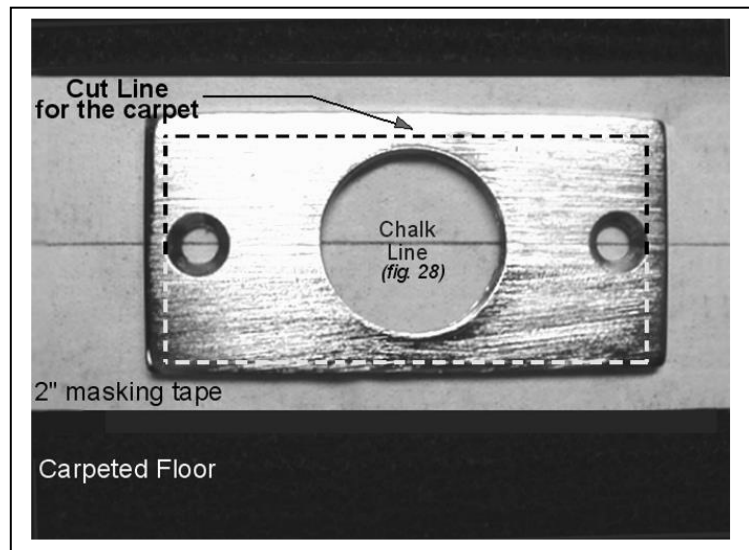
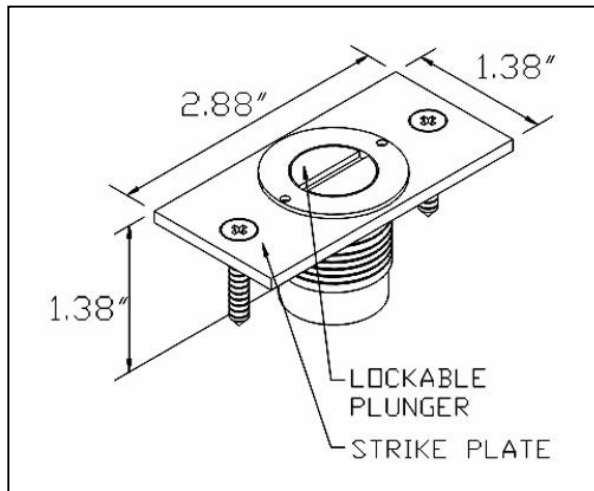
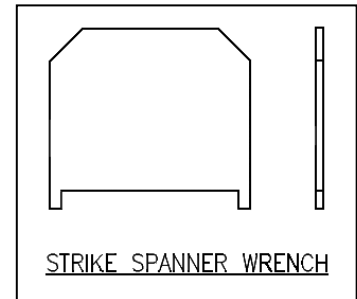
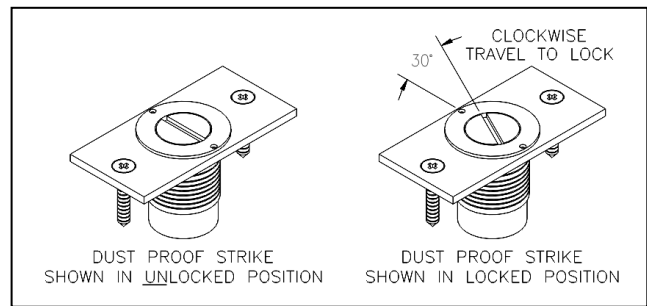

Figure 42: Strike Plate Installed on Carpet

Dust Proof Strike for Floor Bolts



Figures 43: Dust Proof Strike & Wrench



Installing Panels on the G150 Track System

Instructions for installing panels when the finished ceiling is installed in a G150 Recess Mounted track application.

When ceilings are complete, Modernfold GWS panels on G150 cannot be installed with the trolleys attached to the rails. This is due to the panel angle required to get the first trolley up through the roller access area and into the track. Trolleys must be removed from the panel and installed in the track. Panel height is critical, total clearance at top and bottom combined cannot be less than 1/2".

To remove trolleys from panel

- (1) Remove end caps and covers if applicable
- (2) Loosen the two 5/16 screws at the end of the rail until finger tight.
- (3) Loosen the set screw in the trolley block.
- (4) Loosen the lock nut on the trolley bolt.

This will allow the trolley block to slide out of the prep block. If the trolley and prep block hang up, thread the trolley bolt out until it clears the prep block and can be slid out.

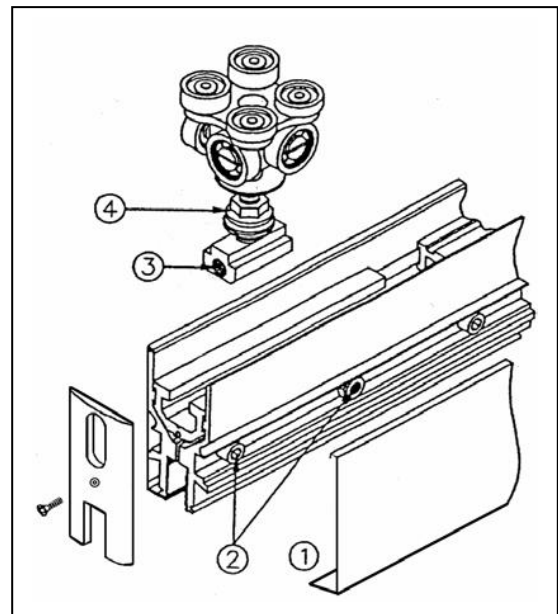

Figure 44: Removing Carrier

Stand panel up between trolley blocks. Slide trolley and blocks into prep block in the rail. Adjust panel up with trolley nut until top rail is approximately 3/8" from track. Tighten trolley nut. Tighten trolley block set screw. Move panel to stack weldment for final adjustment. Once panel is adjusted, tighten the two 5/16" screws at each end of the rail to 15 ft/lbs.

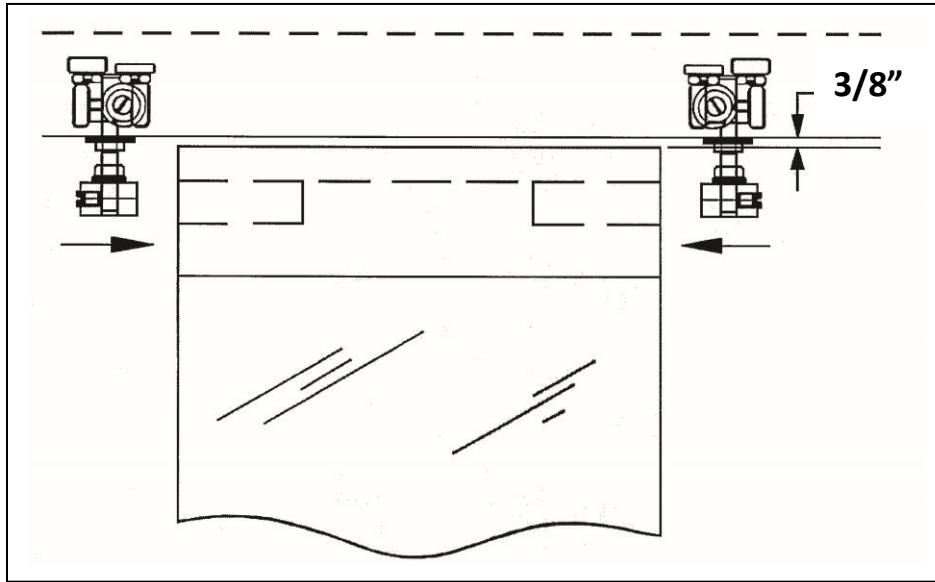

Figure 45: Reinstalling Trolleys

Install End/Pivot Panel

Reinstalling Trolleys Refer to page 18 of this Manual.
The End/ Pivot panel is installed on G150 Track the same as on #17G track.

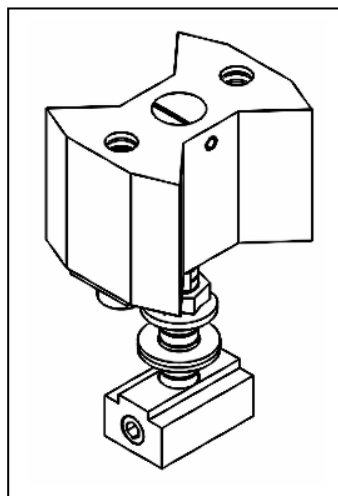
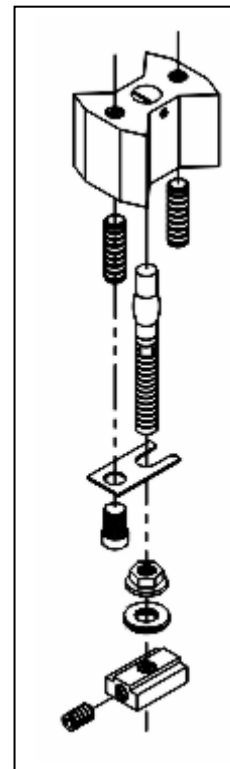
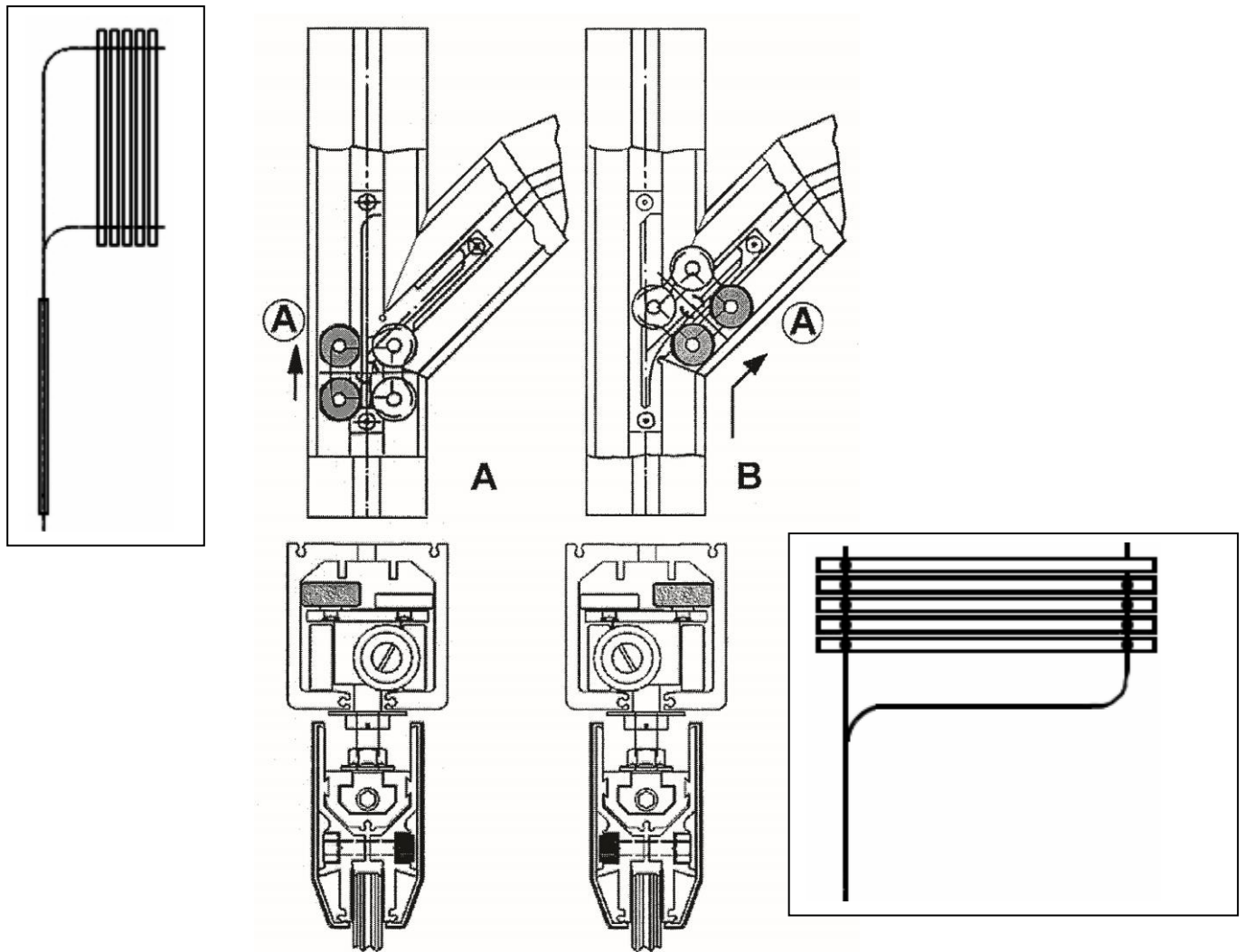

Figure 46: G150 Top Pivot Assembly



G150 Trolley Configuration

The formation of the trolleys has its importance in the stack entrance. Detail-A: For the trolley to run straight through, position the high diverting roller opposite the direction of the parking unit legs. Detail B: For the trolley to divert onto the offset parking leg, position the high diverting roller in the track on the same side as the stacking legs.



Figures 47: Positioning Diverters on G150 Trolleys

Installing Pivot Panel Hardware

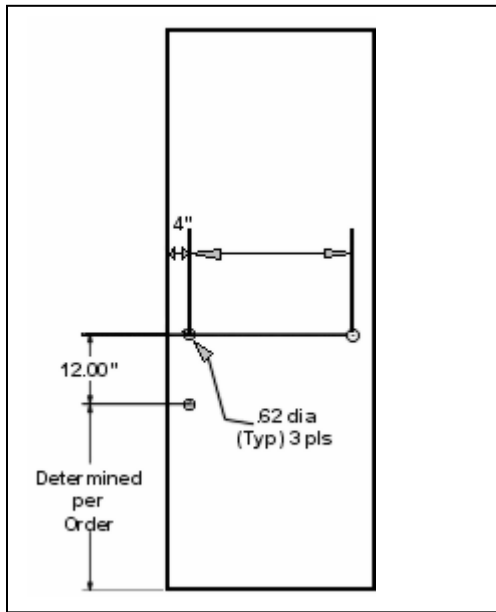

Figure 48: Door Pull Location

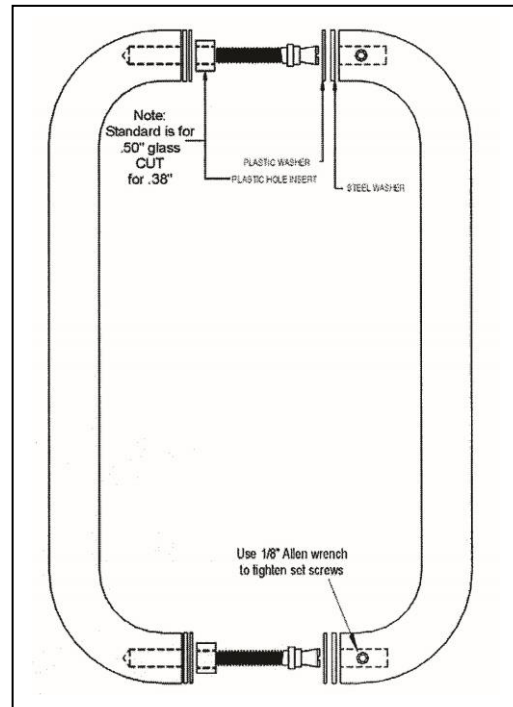

Figure 49: Installing Door Pulls back-to-back

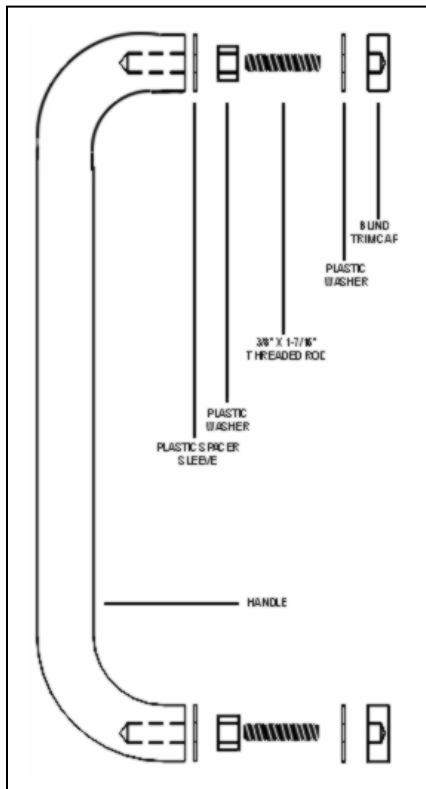

Figure 50: Installing Door Pull one side only

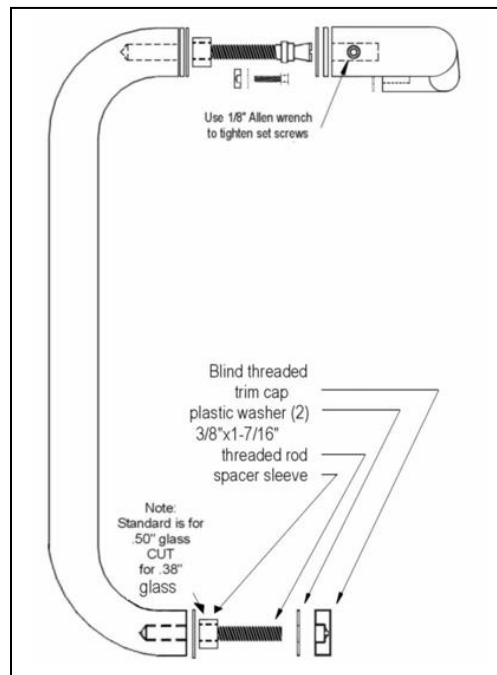

Figure 51: Installing Door Pull and Push Bar

Pivot panels Door Pulls and push bars can be specified several different ways. Door Pulls can be installed on both sides or just one side only. There is also the Door Pull and push bar combination. Although the Door Pulls look similar, each specific Door Pull has its own type of installation hardware. Single Door Pull applications utilize a threaded stud that is secured to the reverse side by a finished cover/nut. Back-to-back Door Pulls are attached *similarly* to the Modernfold latch #72, they have a pin that threads into one half of the Door Pulls the other Door Pull slips over the machined end of the pin and is secured to the pin by tightening a set screw in the Door Pull. That set screw requires a 1/8" allen wrench. The combination Door Pull and push bar uses hardware from both of the previous styles. See the previous page for sketches. All of the Door Pulls are furnished with plastic sleeves and plastic washers. It is important to make sure these are installed to help protect the glass.

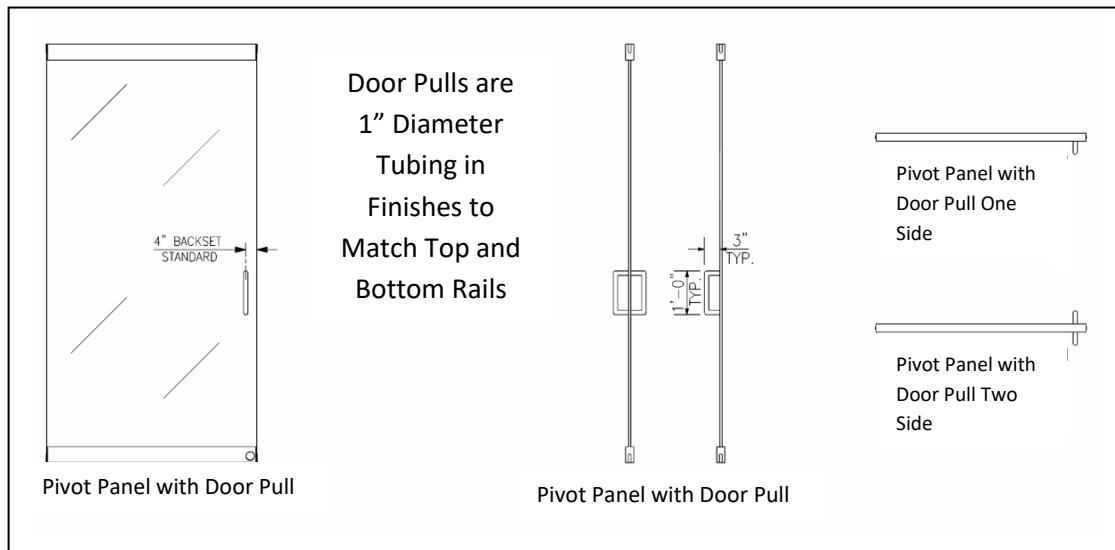

Figure 52: Single and Back-to-Back Door Pulls

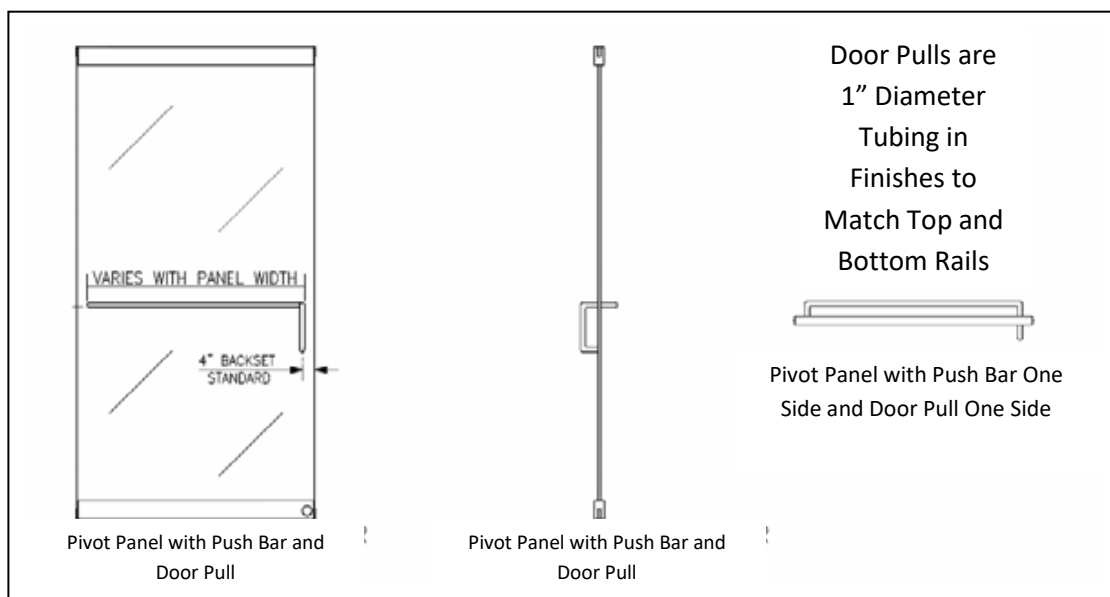

Figure 53: Door Pull and Push Bar

BTS 80 Closer User Adjustments

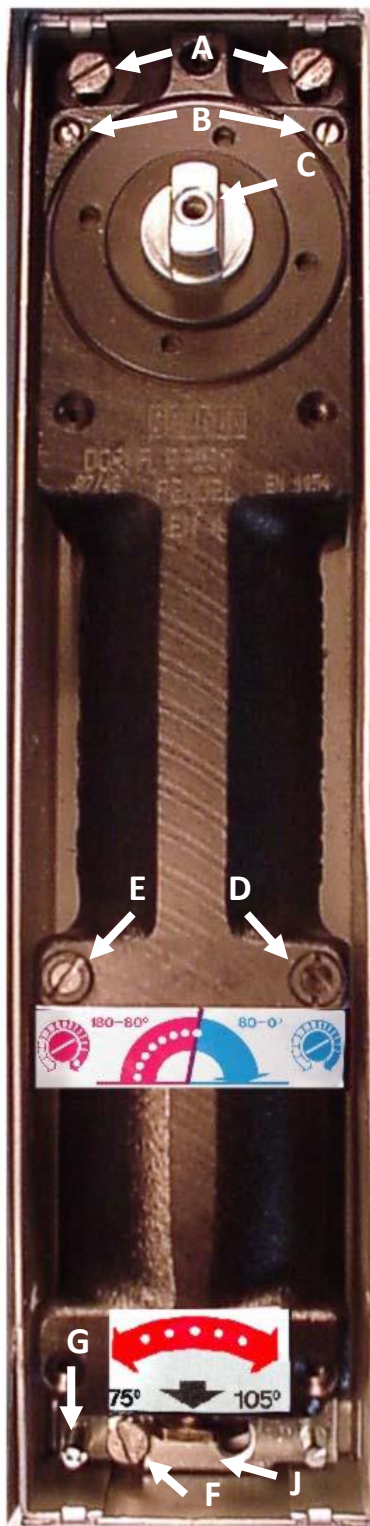

Figure 54: Closer Adjustment Points

Legend for BTS 80 Closer

- A** = Screws that attach closer to box
- B** = Height adjustment screws
- C** = Fixing screw for spindle insert
- D** = Regulating valve for closing speed from approx. 80° to 0°
- E** = Regulating valve for closing speed from 180° to approx. 80°
- F** = Screws that attach closer to box
- G** = Height adjustment screws
- J** = Regulating screw for adjustment of hold-open start.

To adjust the height and level of the closer loosen screws A & F (3). Then adjust screws B & G (4) until desired results are achieved. Clockwise rotation will raise, counterclockwise will lower closer. Retighten A & F screws.

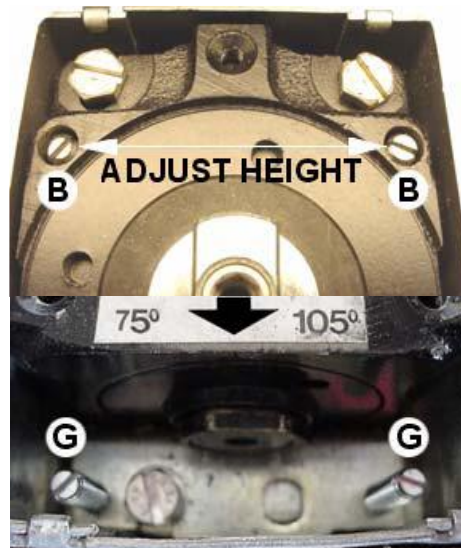

Figure 55: Cutaway View of Height and Level Adjustments at the Top and Bottom of the Closer

BTS 80 Adjusting the Hold Open

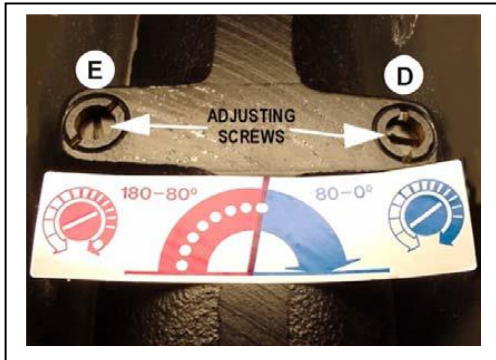

Figure 56

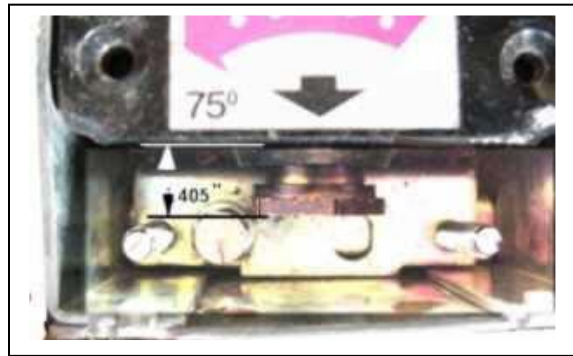

Figure 57



Figure 58

To engage the hold open function of the closer, turn valve "E" clockwise approximately 5 or 6 full turns until the valve screw stops at the bottom then adjust valve "J". This valve will allow you to adjust the angle that the hold open engages. Turn valve "J" counterclockwise with a 22mm wrench approximately 6 full turns. The closer is now set for a 75 degree hold open function. Turning the valve clockwise from the 75-degree setting will change the degree of opening by 5 degrees for each full turn of valve "J".



Figure 59

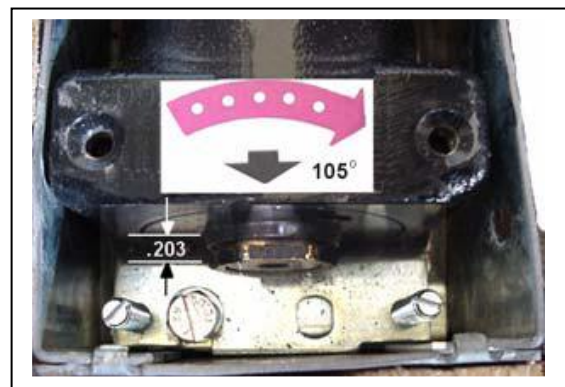

Figure 60

BTS 80 Adjusting the Speed

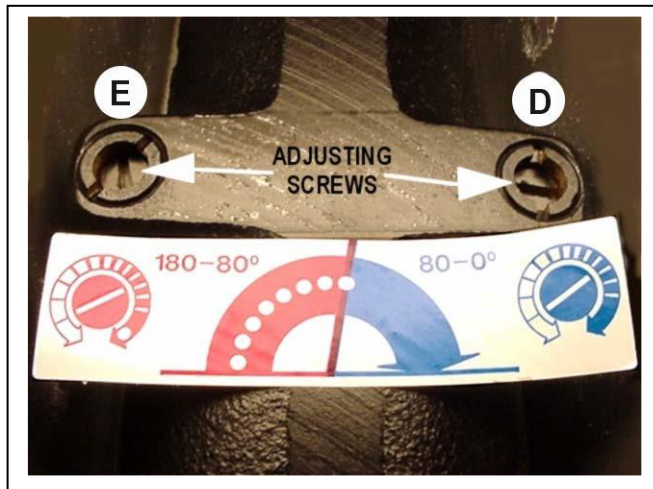

Figure 61: Adjusting the Speed of the Door Swing uses Valve "D"



Figure 62: Location of Valve on Closer



Figure 63: Valve D in Neutral or "OUT" Position

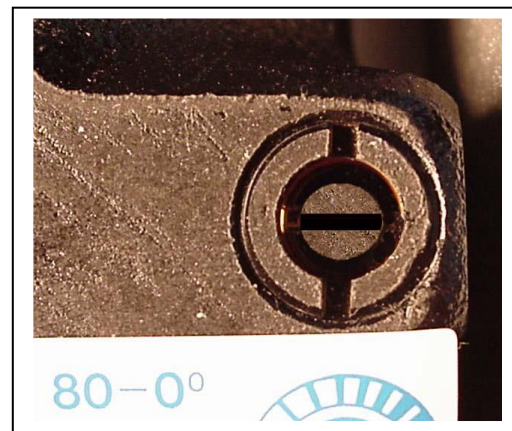
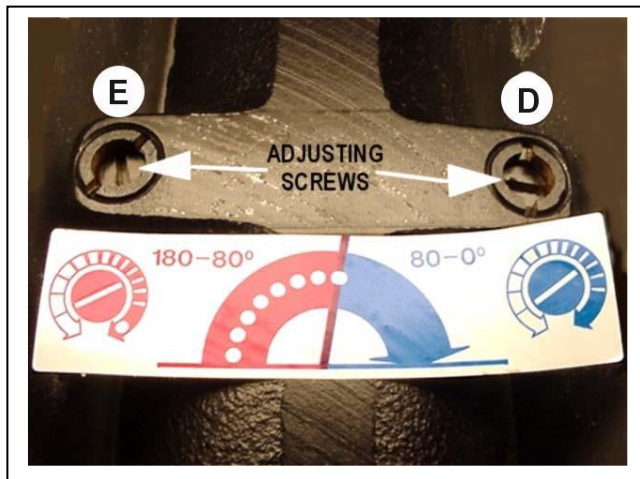

Figure 64: Valve D in Engaged or "IN" Position

Valve "D" controls the speed that the door swings through its arc to the neutral position. When Valve is screwed into the position shown in fig. 58 (1 full turn counter clockwise from "in" position) it will require approximately 25 seconds for the door to return to neutral position from 90 degree opening position. With valve D in "out" position as shown in fig. 57 it requires approximately 5 seconds for the door to return to the neutral position. IN GENERAL, to increase speed door returns to neutral adjust valve counterclockwise to more approximate view in fig. 57. To decrease speed door returns to neutral adjust valve clockwise to more approximate view in fig. 58.

BTS 80 Delayed Closing



Figures 63: Adjusting the Delayed Closing feature uses Valve "E"

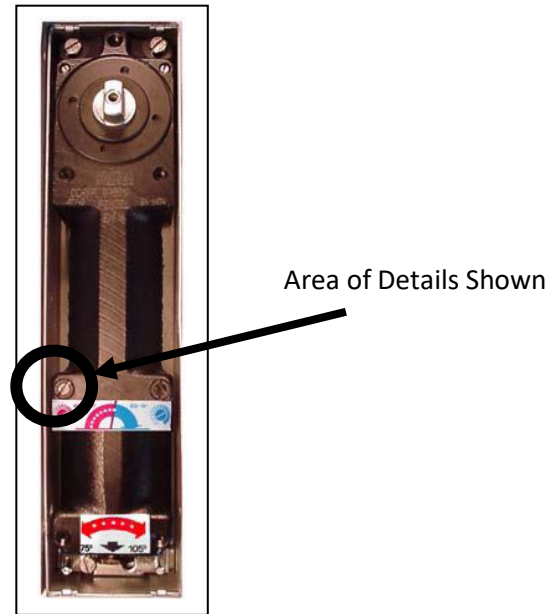

Valve "E" also controls the delayed action movements. When the Valve is screwed into the position shown in fig. 53 (1 full turn counter clockwise from "in position") closer will be in delayed action mode. The door will no longer stay in the open position until manually released but will be moving very slowly until the 70-degree range then it will release and close per settings on the "D" valve. Additional counterclockwise turns on Valve "E" will shorten the delay time.

BTS 80 Last Minute Notes

1. The BTS 80 Closer cannot have both the Hold Open and the Delayed Action Closing engaged at the same time.
2. If valve "D" (speed adjustment) is turned completely to the bottom it will act as a "lock" and the door will not release from the opened position until the valve is manually backed off.
3. If a valve screw has been unscrewed to far it will release from the starting threads on the valve seat. Slight downward pressure with the blade screwdriver is required when restarting the threads.
4. All valve screws have approximately six full turns from the top to the bottom of the valve seats.

Step 6: Operation

General Operation

Once the installation is complete, the partition needs to be checked for proper operation. Following the procedures outlined here will help to ensure that the Modernfold GWS partition operates as specified.

Safety Precautions

To insure proper and safe operation of Modernfold GWS partitions and to prevent damage to them, please use the following guidelines:

- Raise floorbolts before moving a panel
- Always move panels at a walking pace
- Keep hands and fingers clear of meeting edges and pivot points
- Be sure that the path of the partition on its track is clear of any obstructions

Extending the Lead Panel

To begin extending the partition, face the stack and grasp the edges of the panel closest to you. Pull the panel forward, allowing it to follow the track configuration until both trolleys are positioned in the main track. Extending the Lead Panel: Move the panel across the opening until it moves the opposite wall. Move slowly to avoid damaging wall. Bottom of panel will bump base mould.

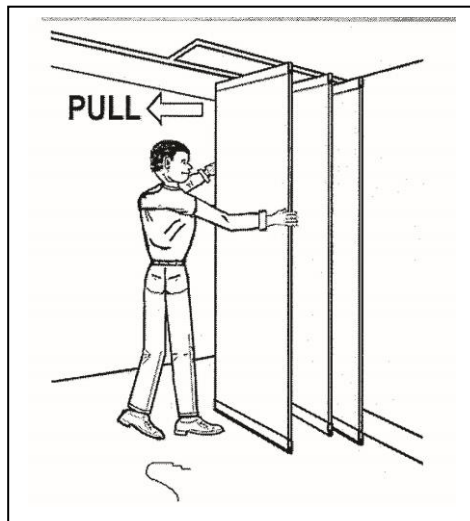

Figure 64: Beginning to extend the panels

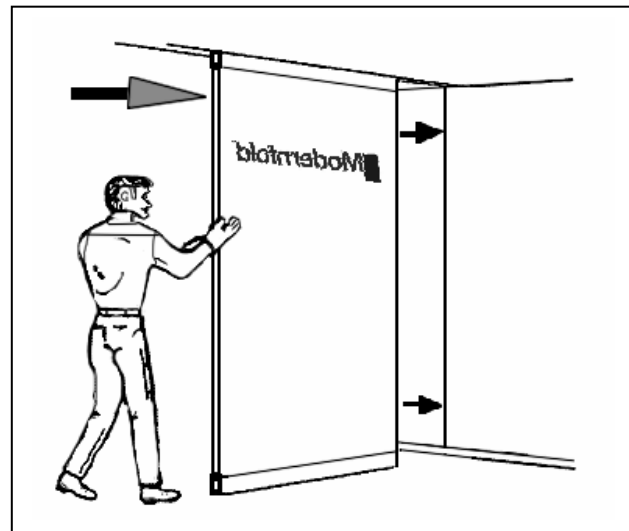

Figure 65: Positioning the Lead Panel

Set Bottom Rail Locking System

Engage adjacent panels by use of interconnecting floor bolts to stabilize panels from movement in all directions.

1. A minimum of one end panel will have a brass mortised lock with a cylinder and/or thumb turn operation. A round bolt will engage a dustproof floor strike for security.
2. Closure Pivot Panels will have a keyed cylinder and thumb turn knob.
3. Intermediate Panels will have interconnecting floor bolts.
4. Lead panels will have a cylinder with a thumb turn.



Figure 66: Key lock Cylinder in unlock position (bolt hidden)



Figure 67: Thumb Turn knob in unlock position



Figure 68: Thumb Turn knob in locked position

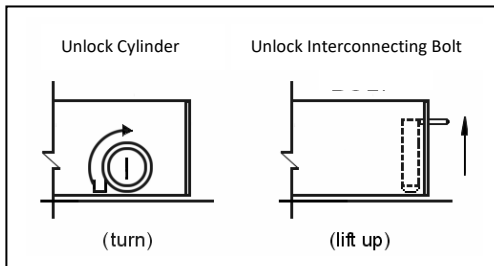

Figure 69: How to Operate Locks When Unlocking System

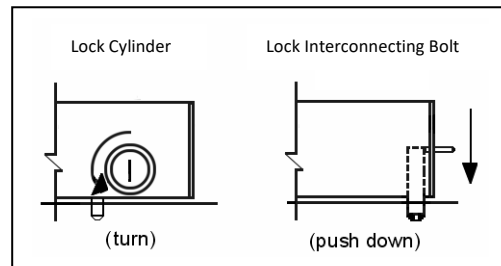

Figure 70: How to Operate Locks When locking System

After moving panel into position, engage the floor bolts. The successive panel will not be able to be set in position if the interconnecting floor bolt is not engaged.

Lock and Interconnecting Floor Bolt Configuration

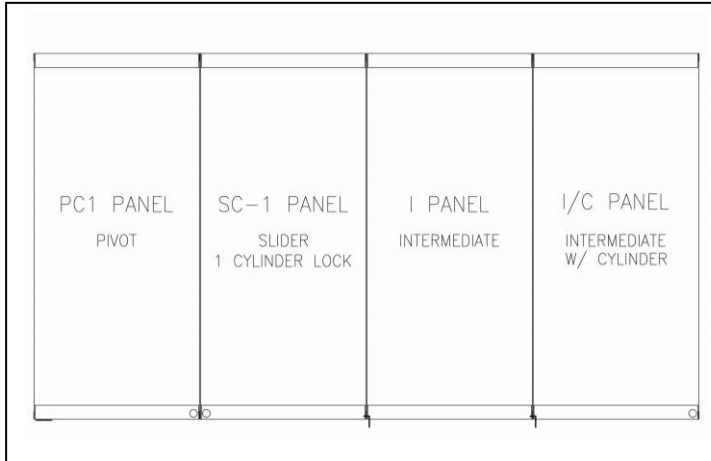

Figure 71: Typical layout

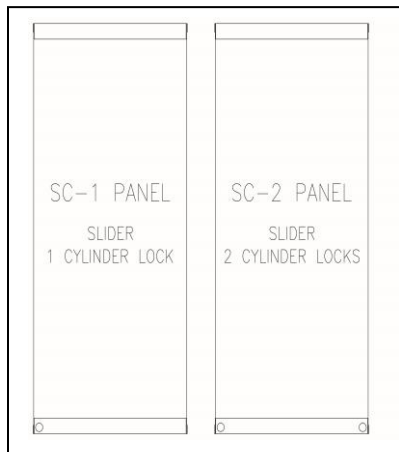

Figure 72: Cylinder lock configuration

Extending the Remaining Panels

Continue to pull the remaining panels from the stack and push them into their proper positions. **Again, remember to move the panels at a walking pace and to be careful of hands and fingers near the panel joints.** Set the floor bolts as required, depending upon the type supplied with each panel.

Completing Final Closure

Once the partition is fully extended, you must complete the closure at the stack end of the opening. The method of closure depends upon which type has been specified for your partition. Floor Pivot – Unlock from stack position and re-lock in open position BTS-80 - Unlock from stack position and release. Will close automatically based on your settings.

Stacking the Partition

When the partition is no longer needed, it can be stacked together to reopen the space. To stack the Modernfold GWS partitions, the procedure is roughly the reverse of extending the partition. **Be sure to release any floorbolts or other locking mechanisms before attempting to move any panels.**

Stacking the Panels

Once the floor bolts are released and the closure panel is stacked, you can begin to stack the panels. Pull the panel closest to the stack away from the panel ahead of it and, *moving it at walking speed*, slide it to the stack end of the opening. Slide the panel out of the main track and into its stack configuration. The layout of each will determine the method you use to move the panel into the stack.

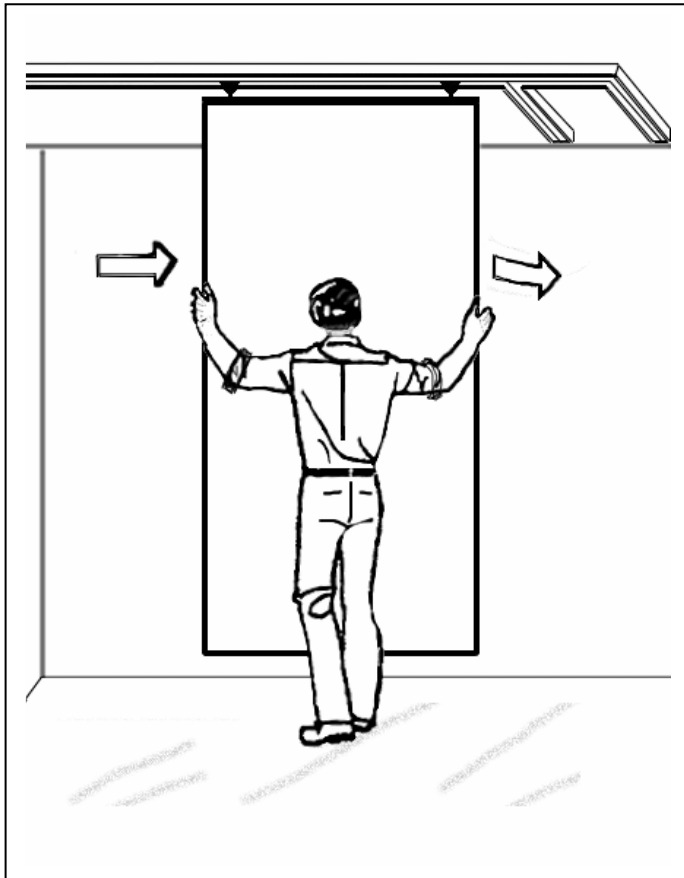

Figure 73

Special Note: Stacking the partition normally requires *finesse*, rather than *force*. Each stack configuration is designed to allow the panels to flow smoothly into the stack area. Switch & curve intersections provide another level of ease in stacking the partition and require minimal effort. Some applications require that the panels are stacked at a slight angle to the fixed wall. **Do not attempt to force the panels into a flat stack.** Also, take care not to force panels into the next panel in the stack, move each panel against the previous one in the stack, then return to the remaining panels and stack the next one.

Step 7: Maintenance

By maintaining your installation after it is complete, you can keep this operation and appearance in good condition for many years.

Track Maintenance

Tracks should be cleaned yearly. Use a mop, or a rag dampened with mineral spirits, to thoroughly clean the inside surfaces of the entire track layout. After cleaning, apply a light coat of petroleum jelly (Vaseline®) to the entire surface upon which the trolleys run. After the first and third years, check the track for proper level and readjust as necessary. This is particularly important on long spans, as truss deflections generally show up within the first three years.

Panel Maintenance

The panels should be periodically checked for damage and repaired as necessary. Regularly inspect all floor bolts and operate the closure. Any adjustments necessary should be made and/or any damaged or inoperable parts should be replaced. After the first and third years of operation, panel vertical edges should be checked for plumb, and, if necessary, plumbed again by adjusting the trolleys. (This can also be a result of header deflection.) Then reset the trolley lock nut to secure the panel.

Step 8: Reference Details

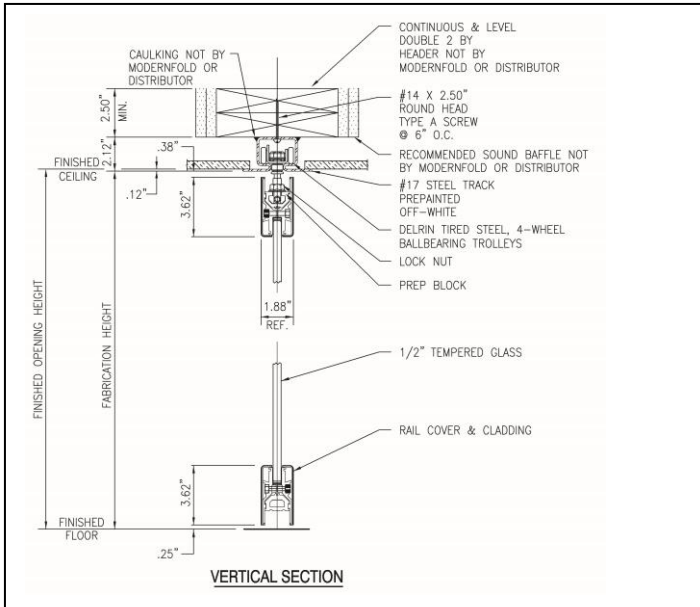

Panel Section ~ Model
 362SR, #17G Track System
 Direct Mount

Figure 74

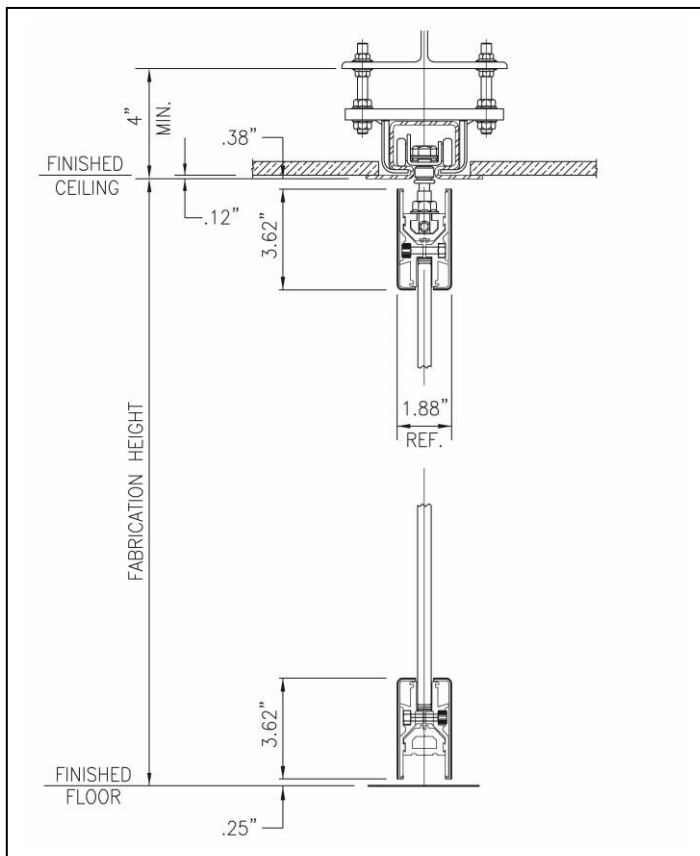

Panel Section ~ Model
 362SR, #17G Track System
 Bracket Mount

Figure 75

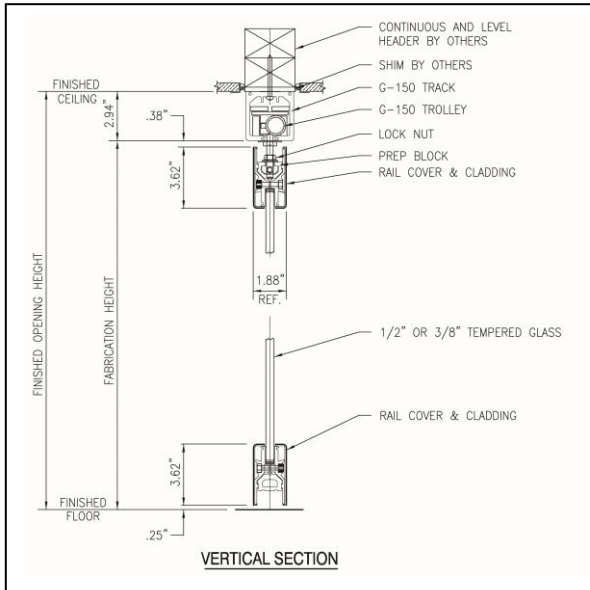

Figure 76

Panel Section ~ Model
 362SR, G150 Track System
 Direct Mount (Surface)

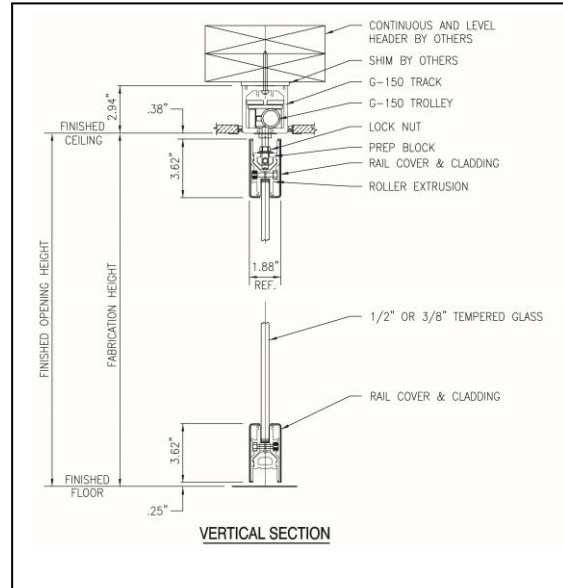

Figure 77

Panel Section ~ Model
 362SR, G150 Track System
 Direct Mount (Recessed)

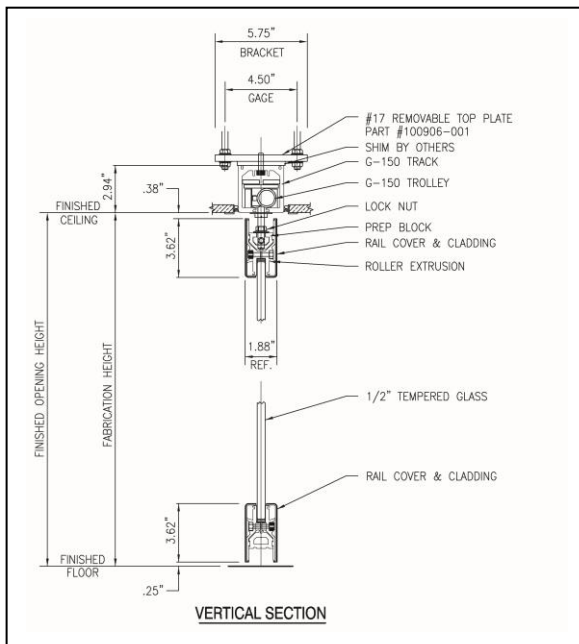

Figure 78

Panel Section ~ Model
 362SR, G150 Track System
 Bracket Mount (Recessed)

Step 9: Reference Page

The following is a random list of standard reference points that you may need to refer to while installing this DRS product.

- | | | |
|--|---|-----------------------------|
| 1. Top gap | Top of rail to bottom of track | 3/8" |
| 2. Bottom gap | Bottom of rail to top of finished floor | 1/4" |
| 3. Panel to wall | Lead edge to wall reference | 3/8" standard see drawing |
| 4. Panel to wall | Trail edge to wall reference | 3/8" standard see drawing |
| 5. Edge to edge | Panel 1 lead to panel 2 trail gap | 1/4" |
| 6. Interconnecting floor bolt & Key thumb turn throw | | 11/16" nominal |
| 7. Floor strike depth | | 1-3/8" |
| 8. Trolley backset | | 2.50" standard 1.0" minimum |
| 9. Floor pivot | without handles on PC1 | 2.50" + dwg ref. |
| 10. Floor pivot | with handles on PC1 | 4.50" + dwg ref. |
| 11. BTS-80 | without handles on PC1 | 2.50" + dwg ref. |
| 12. BTS-80 | with handles on PC1 | 4.50" + dwg ref. |

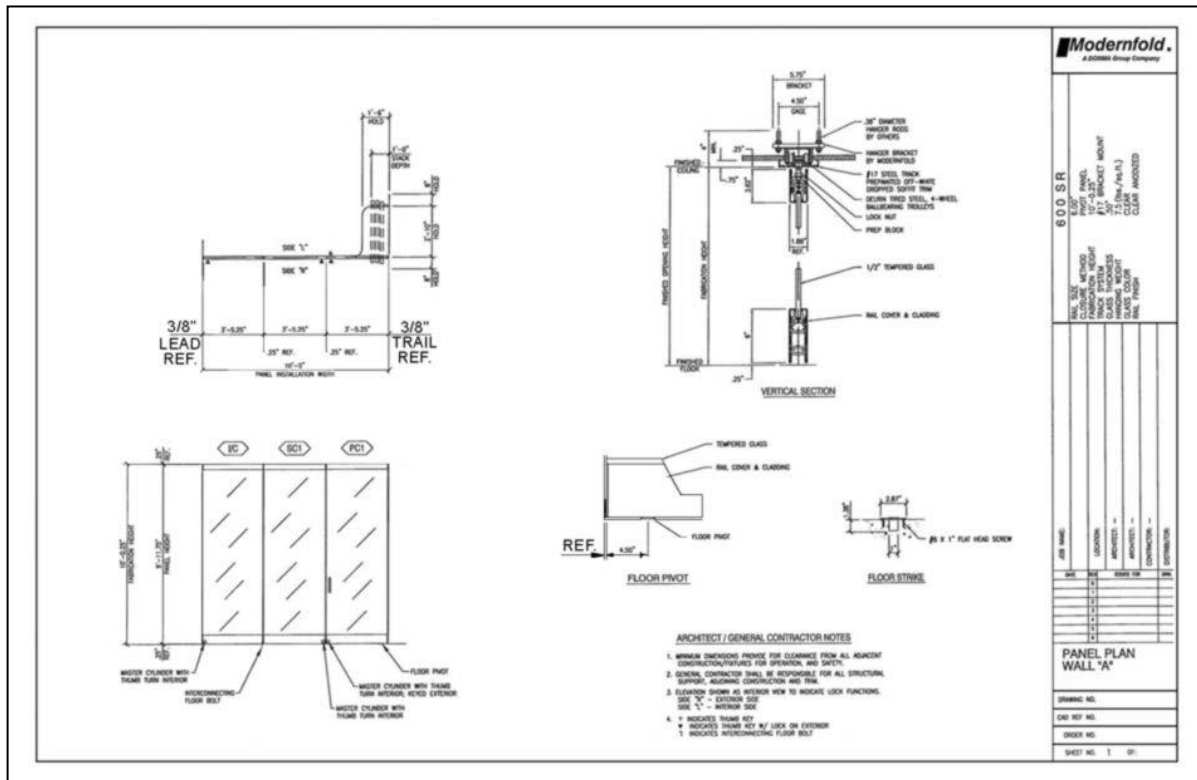

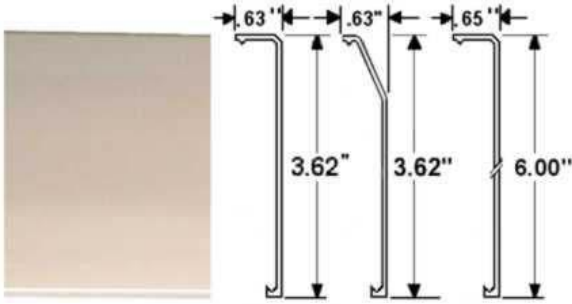
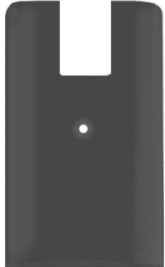





Figure 79: Typical SHOP DRAWING with reference dimensions highlighted. These can vary from installation to installation.

Step 10: Hardware Items

	<p>CLOSER, BTS 80 Z w/ adjustable hold open</p>	<p>300122-002</p>
	<p>COVER, BTS 80 Z Bottom pivot</p>	<p>300326-001-220 "-00x" signifies a COLOR choice is available</p>
	<p>COVER, Rail 362 SR COVER, Rail 362 TR COVER, Rail 600 SR</p>	<p>300204-00x 300205-00x 300206-00x</p>
	<p>END CAP square w/o slot 362 SR</p>	<p>300237-001</p>

	<p>END CAP tapered w/o slot 362 TR 300240-001</p>	<p>300240-001 300241-001</p>
	<p>END CAP tapered with slot 362 TR</p>	<p>300241-00x 300240-001</p>
	<p>HANDLE and PUSHBAR kit</p>	<p>300182-00x</p>
	<p>HANDLE, Double kit 12"</p>	<p>300183-00x</p>

	<p>HANDLE Single, 12"</p>	<p>300181-00x</p>
	<p>INSERT, end cap, std. INSERT, end cap, w/hole K INSERT, end cap, w/slot</p>	<p>300099-001 300100-001 300101-001</p>
	<p>PIVOT TOP G150, DRS rail</p>	<p>300131-002</p>
	<p>PIVOT TOP 17G DRS rail 300097-002</p>	<p>300097-002 300092-001</p>

	PIVOT, FLOOR 8852	300213-001
	ROLLER CARRIER G150 heavy duty	300136-002
	ROLLER CARRIER G150 standard for 90 deg "L" & "T" Applications	300137-002
	SPLICE Pin G150 track	300177-001

	<p>SPLICE Tab #17G track (for direct mount)</p>	<p>103091-001</p>
	<p>STRIKE dustproof PC</p>	<p>300214-00x</p>
	<p>TRACK section G150, removable</p>	<p>300086-001</p>
	<p>TROLLEY assembly w/delrin wheel, #17G</p>	<p>300034-002</p>

	<p>STOP, track #17G (should be installed during installation of preliminary)</p>	<p>107242-001</p>
	<p>STOP, track G 150 (should be installed during installation of preliminary)</p>	<p>300096-001</p>
	<p>SPLICE Bracket #17G Track (for bracket mount only)</p>	<p>110998-001</p>
	<p>Removable Bracket #17G Track (for bracket mount only)</p>	<p>110998-002</p>

IDENTIFICATION FOR THE DISTRIBUTOR

This label with the appropriate numbers applied is installed on the top retainer between the sweeps of the panel assembly. It can help you later, if this partition should ever need repairs.

ORDER # _____	LEAD
WALL: _____	→
PANEL # _____	EDGE

IDENTIFICATION FOR THE END USER

This label is installed on the trail edge of the number one panel on your partition.

	FOR SERVICE AND PREVENTATIVE MAINTENANCE CALL 1-888-FX WALLS FOR YOUR AUTHORIZED SERVICE CENTER
	JOB # _____



215 West New Road
Greenfield, IN 46140

Toll Free: 800.869.9685

email: info@modernfold.com

www.modernfold.com