

INSTALLATION MANUAL

PRESTO PACKAGE

FOR PARTITIONS 200' TO 300'



215 WEST NEW ROAD GREENFIELD, IN 46140

ABOUT YOUR MODERNFOLD PARTITION

Thank you for choosing a Modernfold Operable partition system. As an industry leader in the moveable partition concept, Modernfold delivers the highest-quality, custom partition solutions from start to finish. Our operable partitions and architecturally striking glass partition systems wow customers and provide them with endless possibilities for their environments. Where others see only space, Modernfold sees possibilities.

Before installing a Modernfold partition, read this manual carefully as it includes safety warnings, a description of the wall's major components, as well as procedures related to the operation of the partition, and a maintenance schedule.

Use of Modernfold Partitions can result in serious injury or death. Be alert to the possibility of pinching or crushing injuries where the panels retract into the stack, where the panels seal off when extending, and at the locations where two panels meet. Hazards at all these locations could result in serious injury to a person who may be struck, trapped or pinched by moving Partitions. Modernfold Partitions should only be operated by adults who have been trained in their safe operation.

For these safety reasons, Modernfold partitions should only be used in conjunction with Modernfold control boxes that have been tested to work as designed by Modernfold. Use of Modernfold partitions with any other control devices will void the warranty and be at your own risk.

Table of Contents

Presto Package 200' to 300'

Product Safety	Page 3
Introduction	Page 4
Required tools	Page 5
Step 1 – Touchscreen Controller Wall Mounting	Page 6
Step 2 – Sensor Mounting	Page 7
Step 3 – Sensor Connections	Page 8-9
Step 4 – Calibration	Page 10-13
Step 5 – System Test	Page 14-15
Step 6 – Maintenance	Page 16
Step 7 – Troubleshooting	Page 16
Appendixes	Page 17
Appendix A	Page 17
Operation see Owner's Manual 8305	

Warnings and Safety Information



WARNING

Operable partitions pose a pinching and/or crushing hazard. To avoid serious injury or death:

- **Do not** operate your operable partition with persons or objects within 4 feet of the operable partition or the partition path, including the stacking area.
 - **Do not** walk or place body parts in front of the partition or into stack area while partition is moving.
 - Ensure no other persons enter the partition path, including the stack area, while wall is moving or being operated.
 - Ensure that both sides of the operable partition, as well as the partition path, are clear of obstructions.
-
- After installation, the entire system, including all sensors, should be carefully tested to ensure safe and normal operation. Extreme care should be taken during testing to remain clear of moving walls to avoid possible injury.
 - Never leave the area while operating the wall during installation, maintenance, or normal operation.
 - Operable partitions may be regulated by local, state, or district rules and regulations. All applicable rules and regulations should be reviewed before installation and use.
 - Operators must be above the **age of eighteen (18)** and trained in the safe operation of the partition and understand its safety features.
 - **Do not** place objects between the panels, in the path of the operable partition, in the stack area, or in the near vicinity of the operable partition as this can damage the operable partition when it is in motion.
 - In case of malfunction, **do not** operate the operable partition or attempt to repair it. Contact your authorized local operable partition dealer for service.
 - **Do not** operate your operable partition if it is making any abnormal noises or if the operable partition does not appear to be working properly. Contact your authorized local operable partition dealer immediately.
 - **Do not** operate your operable partition if a panel is loose or displaced from its normal securely fastened position.
 - **Do not** operate your operable partition if panels are missing as this can damage the system.
 - Operable partitions are intended only for interior use in which the room is climate controlled.
 - **Do not** force the panels into the stacked position
 - Track systems are designed to support the weight of the partitions only. **Do not** hang anything from the track or the partitions.
 - To prevent floor damage, **only** operate partitions over finished floors which are fully cured and clean of debris (See Manufacturer's Recommendations)
 - The safety features of the wall, including sensors, should never be disabled, bypassed, or overridden. The system should not be operated until all safety features, including the sensors, are properly and completely installed, calibrated, and tested.
 - The safety features of the wall, including sensors, are not substitutes for continuous and careful observation and supervision.
 - Read completely and carefully all included component supplier manuals before installation or operation.

PROCEDURE FOR INSTALLING PRESTO PACKAGE

Purpose

To properly document the correct methods and processes required for the installation of Presto Package Automation System.

Before Beginning Installation

Installation Precautions

- Installation of Modernfold partitions should only be performed by certified trained professionals. Failure to follow this requirement will result in a voided warranty.
- Proper protective equipment should be used on all installations of Modernfold partitions.
- **Do not** alter any track suspension bracketing or hanger rods in any way.
- Turn off power to system and any nearby equipment or cables carrying electricity until completion of wiring.
- Connect all limit and pocket switches before providing power to system and operating wall.

Review drawing and field Conditions

- Make sure you have drawings for fabrication, not approval drawings.
 - Verify opening dimensions against drawings.
 - Make sure existing building partitions are properly reinforced for jamb attachments at each end of the opening.
 - Examine pocket and/or stack area for proper clearance and adequate depth.
 - Look for any job site conditions that could interfere with installation or operation of the partition.
-
- **All discrepancies must be corrected before installation can begin**
 - **Read installation instructions completely before beginning installation**
 - **Call the Modernfold Tech Line if you have problems or questions with installation at 1-866-561-8324**
 - **Verify all parts against the packing list**
 - **Locate and lay out all pieces**
 - **Be prepared to verify track level and straightness with laser or other leveling instruments. Finished track installation must be straight and level.**

Tools Required

Assembly requires common tools as hammers, screwdrivers, tape measures, etc. and:

- Heavy Duty Drill
- Drill Bits (include 9/16")
- 4'-0" Level and/or Laser Level
- Torpedo Level(s)
- Cordless Drill & Various Phillips Bits
- Set of Allen Wrenches
- Rubber Mallet
- Petroleum Jelly (to lubricate track)
- Clean cloths
- Paper towels
- Set of Wrenches
- Socket set

Step 1: Touchscreen Controller Wall Mounting

(Warning: Wall mounting should be done only by an authorized, qualified and experienced professional. Turn off power to any nearby equipment or cables carrying electricity.)

The touchscreen wall mounting box should be placed in a location which allows the operator clear visibility of the partition while it is being retracted and extended. In order for the user to not trip any of the motion sensors during operation, the touchscreen needs to be out of the sensors' line of sight, at least 20' from the centerline of the track.

When the proper location has been determined, a cutout should be made in the drywall approximately 7-1/4" wide by 6-1/2" tall.

Prior to installing the mounting box, run the wires that connect the touchscreen to the main control box (inputs for *A12/A13*, *A14*, *24VDC*, and *TRAIL*) and sensor control box (*RELAY*) from their respective boxes through the wall cutout. Feed the input, output, and power wires through the holes in the sides of the mounting box. The box should be installed in the orientation shown in *Figure 2*.

Insert the box into the wall and once it is correctly positioned, swing the three wall tabs out behind the drywall so that the long ends are pointed away from the box and tighten screws to secure to the wall.

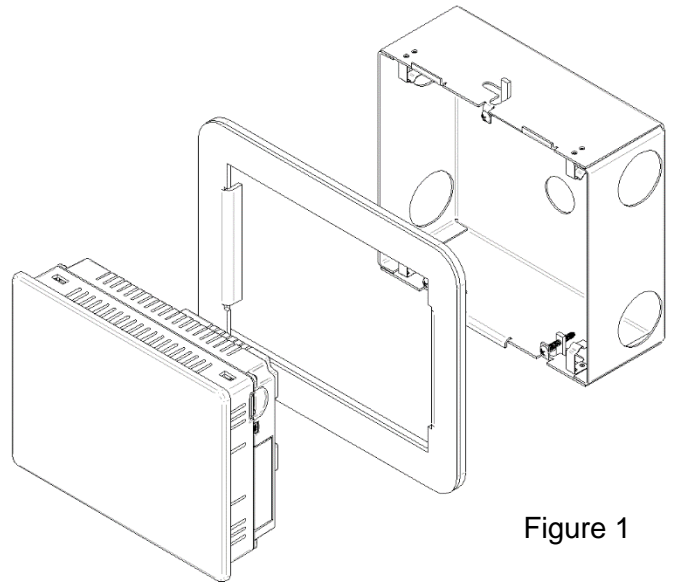

Figure 1

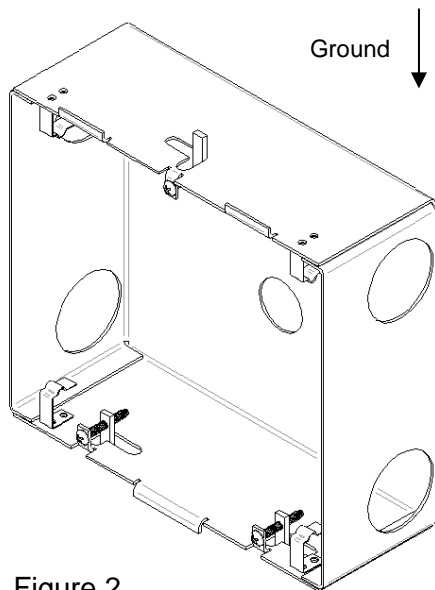

Figure 2

Slide the faceplate with gusset (shown in *Figure 1*) from the rear of the touchscreen until the faceplate sits flush with the front lip of the controller.

Plug the input adapter (15-terminal orange block) into the touchscreen's orange receiving connector (J1). Plug the output adapter (15-terminal black block) into the black receiving connector (J2). Lastly, connect the three loose wires on cable 114614-001 to the corresponding colored wires coming off the touchscreen by matching black to black, red to red, and green to white. Adjust the position of the wires and push the touchscreen controller and faceplate into the mounting box until it clicks firmly into place.

(Note: The spring steel tabs in the wall box that secure the touchscreen might need to be adjusted to properly hold it in place)

Step 2: Sensor Mounting

The (4) motion sensors are to be mounted in the orientation shown in *Figure 3*. There are to be two sensors on each side of the wall, with the beams facing into each other.

Each sensor should be mounted between 9' to 10' off the ground.

The sensors should be mounted 11' from the centerline of the partition.

The sensors are to be mounted to the wall using the provided mounting arm in the orientation shown in *Figure 4*. The sensor aim will be adjusted later during final adjustments.

The wiring harness from each sensor should be run to the sensor control box.

(Warning: The motion sensors are an integral part of the safety system. They are never to be bypassed. The system should not be operated until the sensors are properly and completely installed and calibrated.)

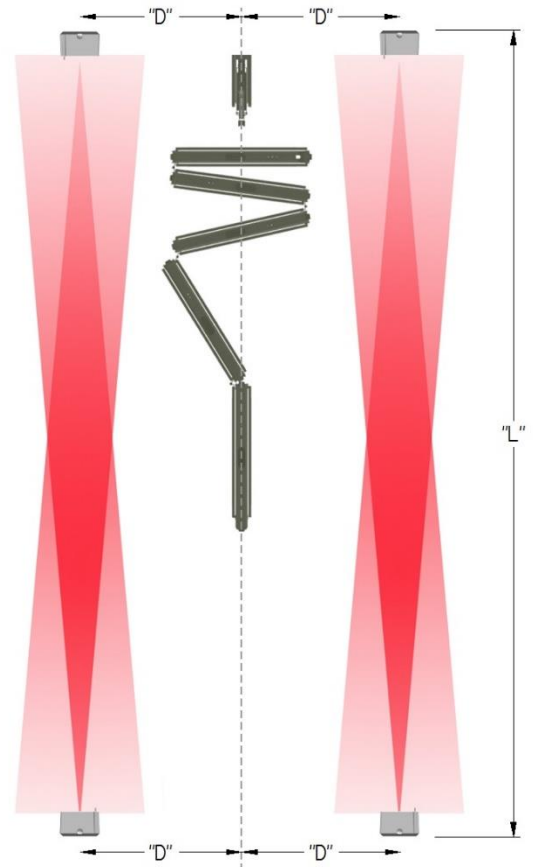

Figure 3

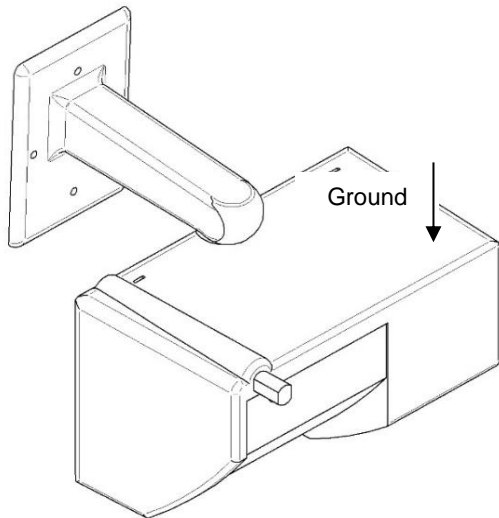

Figure 4

Step 3: Sensor Connections

Sensor Control Box Connection Instructions

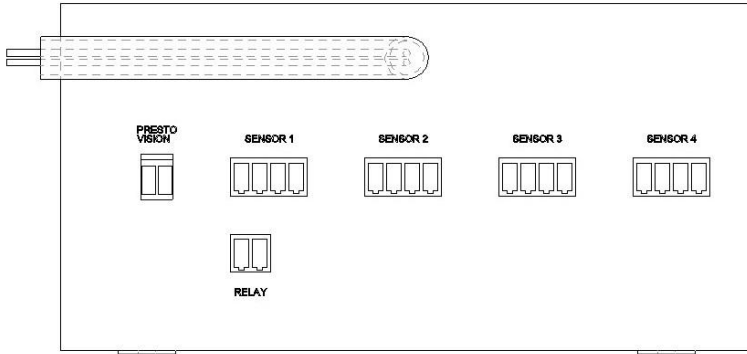

Figure 5

The sensor control box should be installed within 10' of the main control box.

Plug each motion sensor into one of the four sensor ports.

(Note: Sensor order does not matter)

The 2-conductor wire without connectors will be run from the *PRESTO VISION* connection on the sensor control box to the *PRESTO VISION* connection on the main control box.

To do this – using a small flat screwdriver – loosen the screws on the connector to open the terminals. Insert the wires into the terminals and re-tighten the screws.

(See Figure 6)

(Note: Wire order does not matter)

The 2-conductor *RELAY* connection will be run from the output terminal block of the touchscreen to the *RELAY* port on the sensor control box.

(Note: For bi-parting walls with two drive units, two 2-conductor wires will be run from the same *PRESTO VISION* connection on the sensor control box, with one cable going to each main control box)

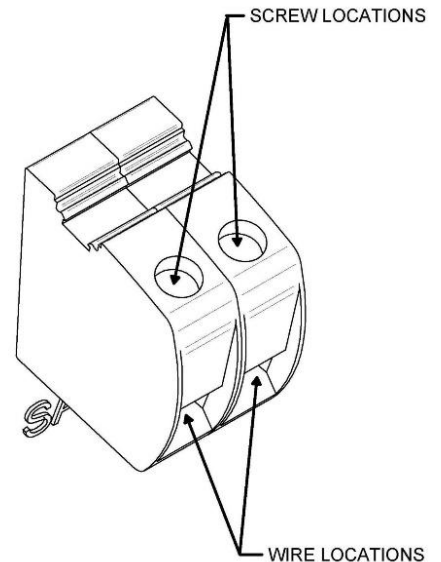

Figure 6

Main Control Box Connection Instructions

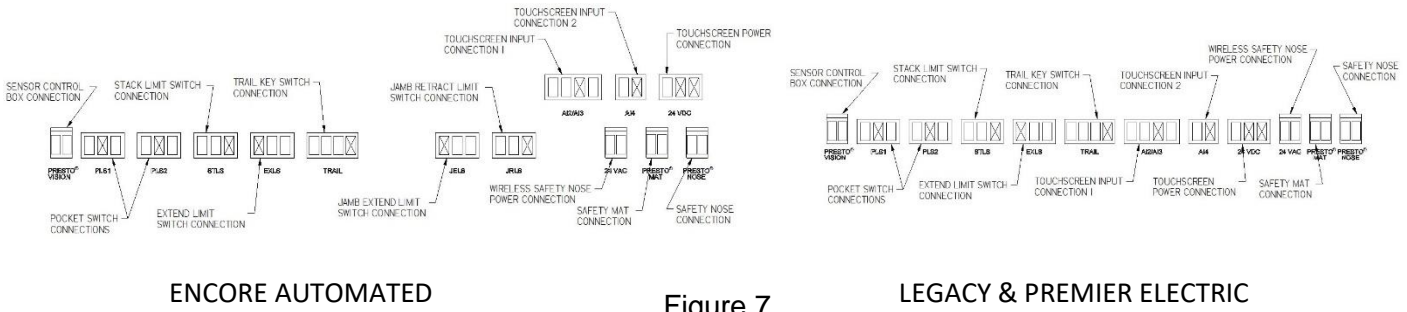

Figure 7

Presto Safety Nose / Presto Safety Mat

(Note: The control box is wired for Presto Safety Mats and Presto Safety Noses. When the Presto Safety Mat detects an obstruction, the wall will not operate in either direction until the obstruction is cleared. The Presto Safety Nose connection is wired to allow the wall to continue retracting when tripped.)

To connect the Presto Safety Mat, insert the ends of the 2-conductor wire running from the Presto Safety Mat into the *Safety Mat* terminals on the main control box. The connection procedure is the same as performed for the *PRESTO VISION* connection shown in *Figure 6*.

Refer to the *Wireless Safety Nose Installation Manual* to complete Safety Nose setup.

Touchscreen Connection Instructions

To connect the touchscreen inputs, plug in the connectors for *A/2*, *A/3*, and *A/4* into their respective ports on the main control box.

To connect the outputs, plug in the connector for *TRAIL* into the port on the main control box.

(Warning: Connect all limit and pocket switches before providing power to system and operating wall)

Step 4: Calibration

Motion Sensor Calibration and Adjustment

Provide power to the entire system. The motion sensors will show a blinking light for up to two minutes while sensing the environment.

Note: To accurately calibrate the motion sensors, remove all objects and persons from the area within view of the sensors until the flashing red light disappears.

Once the first calibration step is complete, adjust each sensor to point as close to parallel as possible to the extended partition.

To accurately determine the sensing zone, the installer needs to walk at a point in the middle of the run from both sides of the beam for each set of sensors pointing into each other. Perform the test focusing on one sensor at a time.

(See Figure 8)

Each sensor displays a color-changing light to indicate its current detection state. A red light signals the sensor has been tripped. When walking into the beam path, it is recommended that the installer places temporary marks on the floor at which each sensor light turns red. Adjust the aim of each sensor and repeat the process until the marks for each sensor are in line with the desired beam position shown in Figure 9.

(Note: Ignore orange or green lights during test)

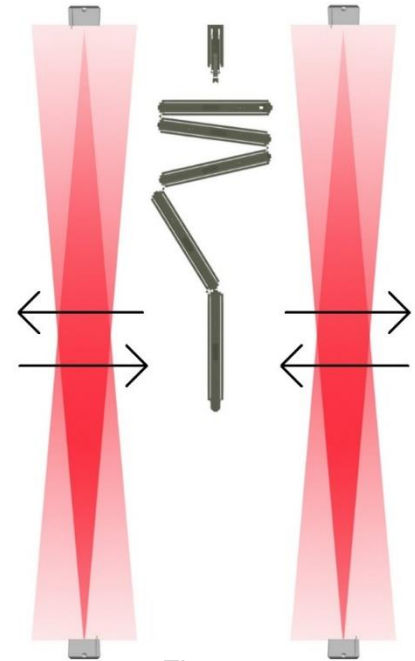

Figure 8

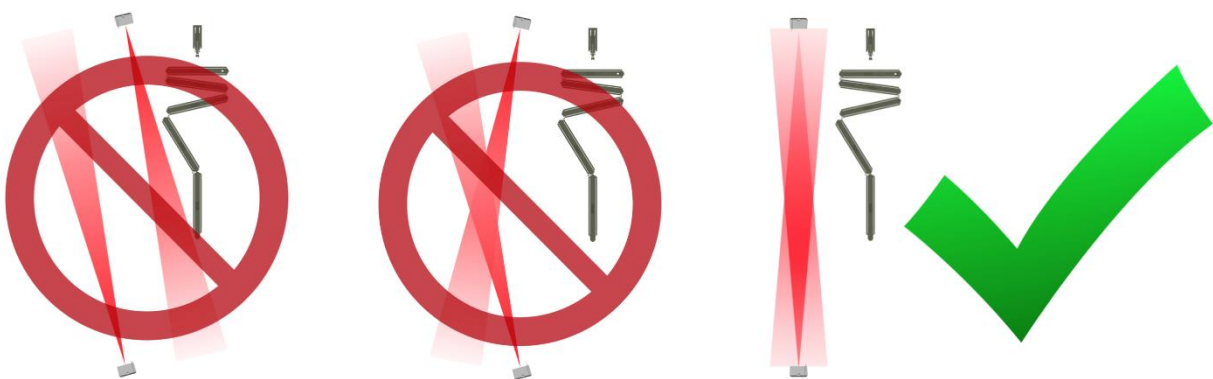

Figure 9

Presto Package Touchscreen Setup

Once sensor setup is complete, the touchscreen system needs to be calibrated for all sensor input signals.

1. Supply power to the device and wait for the main password screen to appear.
2. Touch the password input field and enter the default password (1234). Press *Enter* in the password input field and then again on the main password screen.

(Note: The user password must be promptly changed to a safe and secure, customer chosen, 4-digit number to prevent unauthorized use. This password can be changed by pressing the Password Setup button on the maintenance screen and following onscreen instructions.)



3. If the warning is accepted, the user will be brought to the main menu screen. Press the *Maintenance* button.

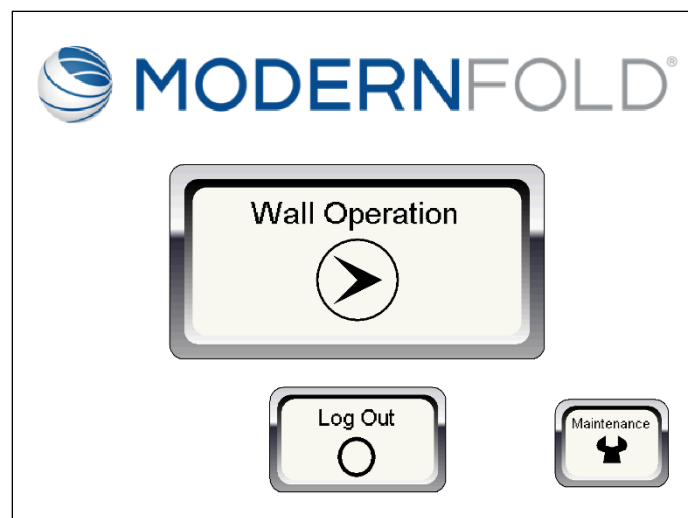

4. Touch the password input field and enter the default maintenance password (3592). Press *Enter* in the password input field and then again on the maintenance access screen.
5. On the maintenance screen, press the *Inputs* button.



6. On the inputs screen, press the *Calibrate System* button.
7. Before beginning calibration, make sure that the motion sensors, Presto Safety Mat, and Presto Safety Nose are powered on and connected properly to the touchscreen system.

(Note: It is essential that the Presto Safety Nose and Presto Safety Mat are not tripped during this process. Calibration is used to find a baseline for each device and activation will result in inaccurate calibration).

8. Press *Calibrate*

(Note: Even after the calibration setup is over, the motion sensors should show a blinking light for up to a couple minutes. Stay out of their field of view until the light stops blinking).

- On the inputs screen, the three graphs show the sensor input signal levels. The red line represents the threshold the signal must reach for a trip to be registered, while the black line represents the signal itself. In order for the system to work properly, the sensor signal must be above the set threshold value when tripped, and below the threshold at all other times. While calibration should produce the correct values, check to make sure that the threshold values are set correctly by monitoring the sensor signals in the tripped and untripped state. If the threshold values need to be adjusted, use the increase and decrease buttons next to the respective graph to raise or lower the corresponding threshold, or touch the threshold value and input the desired level.

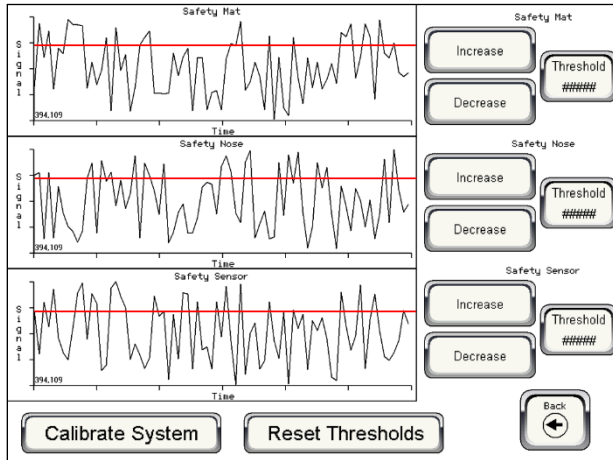

(Note: The desired signal levels for the safety mat and safety nose in their untripped states are low for the scale of the graphs. The signals may be difficult to see but correct values should appear as “bold” Time axes compared to the Time axis on the safety sensor graph.)

- Following calibration, return to the maintenance menu and press the *Settings* button. Pressing the *SYSTEM* button to the right of the screen will lead to the system settings menu.
- By using the arrow keys or by tapping the name, highlight *Set Time/Date* and press *Enter*. Scroll down to *Time Zone*, press *Enter*, and set the correct hour adjustment (e.g., +5:00 for EST) and press *Enter*.
- Make sure *Daylight Saving* is set to *Yes* if location observes Daylight Savings Time. Scroll to the top and adjust the time, date, and day to the correct values under *Local Time*.
- Press *Esc* twice to leave the system menu and return to the program.
- On the maintenance menu, press the *Maintenance Clock* button. Press *Set Maintenance Clock* button to complete setup.

Maintenance Clock

Every controller is set to alert the user with maintenance notifications each year. The user will receive a preemptive notification each day during the 11th month, followed by a final notification each day during the 12th month. The maintenance clock is set exactly 11 months from the current date and time. Following yearly service, it is required that the technician reset the maintenance clock to start a new yearly cycle by pressing *Set Maintenance Clock*.

Step 5: System Test

Wall Operation Test

1. From the home screen, press the *Wall Operation* button.
2. Select either *Extend* or *Retract* based on desired operation.
3. On the operation screens, the *Extend* or *Retract* button must be held for 3 seconds to begin wall operation. After operation has begun, the wall can be stopped at any time by pressing the *Stop* or *Home* buttons.

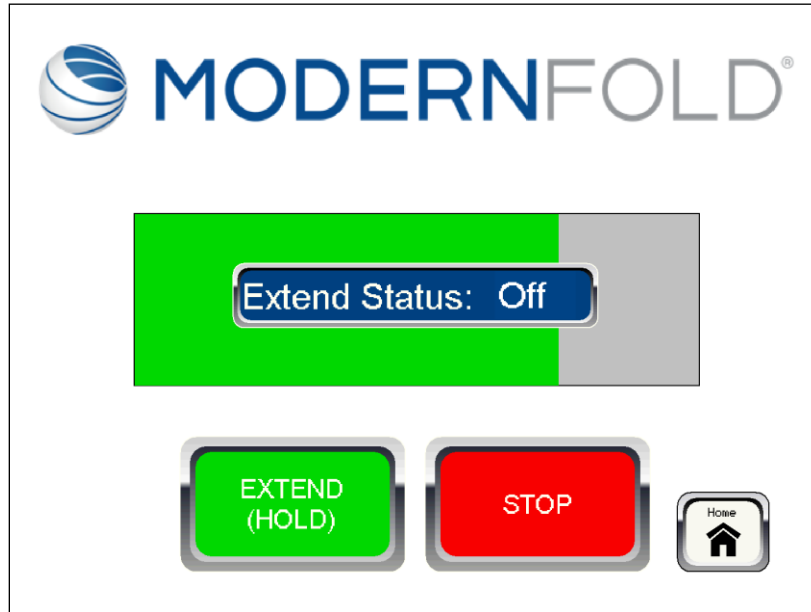

4. Wall operation will be stopped if any of the system sensors are tripped or if the user leaves the operation screen. Logging out will be required if a sensor is tripped while the wall is in operation.



Test Checklist

Complete the following operations to confirm a successful setup procedure:

- Extend Wall
 - Trip motion sensor during extension (*stops wall movement*)
 - Trip safety mat during extension (*stops wall movement*)
 - Trip safety nose during extension (*stops wall movement*)
- Retract Wall
 - Trip motion sensor during retraction (*stops wall movement*)
 - Trip safety mat during retraction (*stops wall movement*)
 - Trip safety nose during retraction (***does not stop wall movement***)

Step 6: Maintenance

The user will receive two types of maintenance notifications in every 12-month period following the last performed maintenance:

1. After 11 months following the last maintenance inspection, an initial notification will appear every day for 30 days notifying the user that scheduled maintenance is required soon.
2. After 12 months following the last maintenance inspection, a final notification will appear every day for 30 days notifying the user that scheduled maintenance is required.

When these notifications appear, contact your local distributor to schedule a maintenance inspection.

Step 7: Troubleshooting

1. Touchscreen inaccurately states that one of the sensors is tripped, or touchscreen is not registering a sensor trip while a sensor is displaying a red light.
 - a. From the *Maintenance* menu, go to the *Inputs* screen. Watch the graphs displaying the sensor input signals. The red line represents the threshold the signal must reach for a trip to be registered, while the black line represents the signal itself. In order for the system to work properly, the sensor signal must be above the set threshold value when tripped, and below the threshold at all other times.
 - b. First, attempt to fix the system by pressing Calibrate System and going through the auto calibration setup. **(Note: Make sure all the sensors are properly connected)**
 - c. If the problem remains, return to the *Inputs* screen. For each sensor, manually adjust the set threshold level by using the increase and decrease buttons next to each graph. Adjust the threshold (red line) until it is comfortably above the signal base line (black line). Repeat this process by tripping each sensor until the desired operation and threshold settings are achieved.
2. Motion sensors are not displaying red light during an action that should cause a trip.
 - a. Power cycle the motion sensors by running through the calibration setup mentioned above. Alternatively, this process can be done by gaining access to the sensor control box and unplugging and plugging back in the faulty sensor or by flipping the breaker that is providing power to the system. **(Note: To accurately calibrate the motion sensors, remove all objects and persons from the area within view of the sensors until the flashing red light disappears)**
 - b. If unplugging and plugging back in sensors or flipping the breaker, go through the calibration process mentioned above. Once calibration is complete, go to the *Inputs* screen and check to make sure the sensor input signals are behaving correctly.

Appendix A

Touchscreen Controller Wall Mounting Box Cutout Template

Cut on dotted line and use template for making a properly dimensioned hole for the touchscreen wall mounting box. (**Note: Do not scale**)

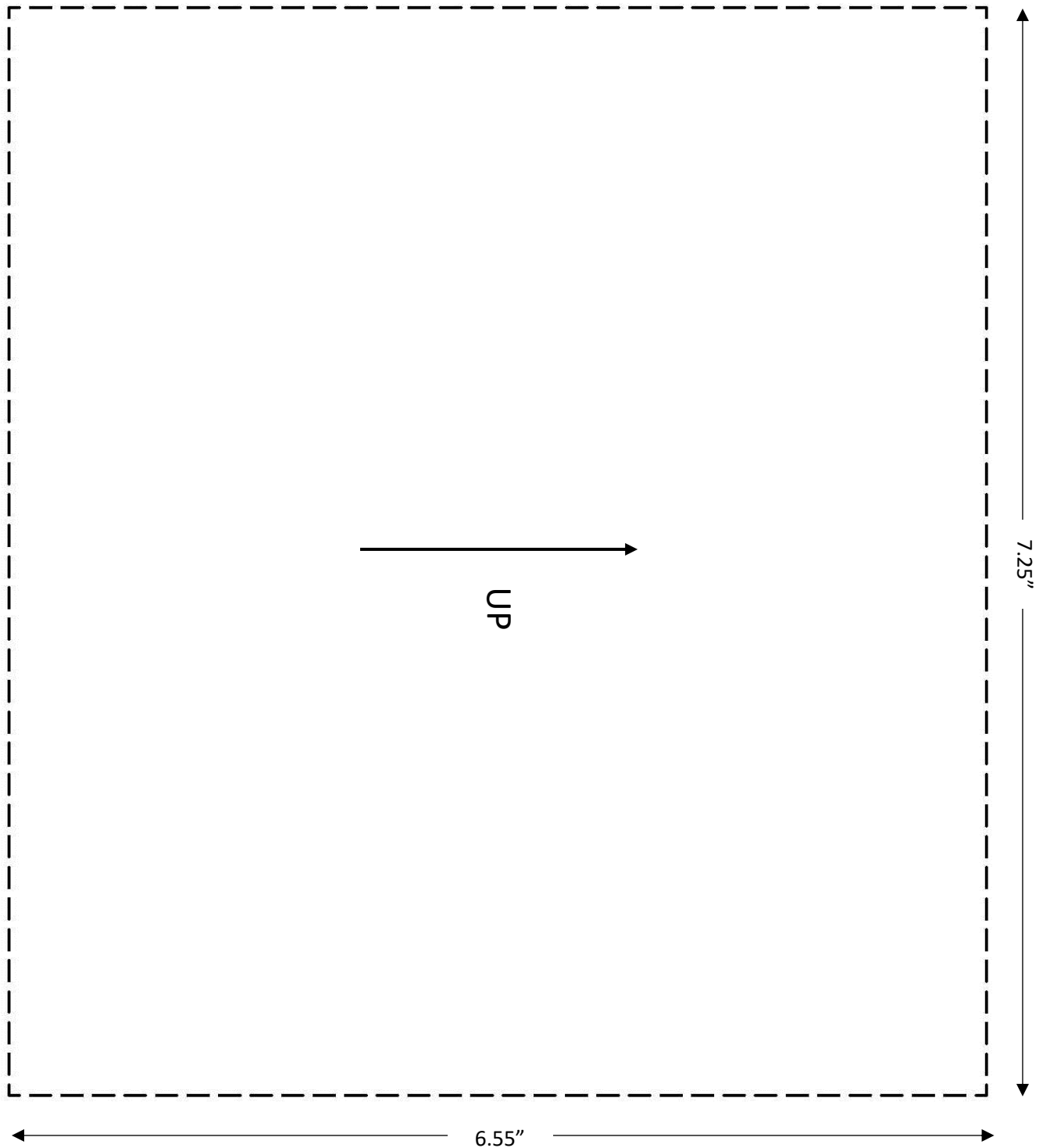

IDENTIFICATION FOR THE DISTRIBUTOR

This label with the appropriate numbers applied is installed on the top of the panel assembly. It can help you later, if this partition should ever need repairs.

ORDER # _____	LEAD →
PARTITION: _____	

IDENTIFICATION FOR THE END USER

Installer Information
Company: _____
Install Date: _____
Job # _____

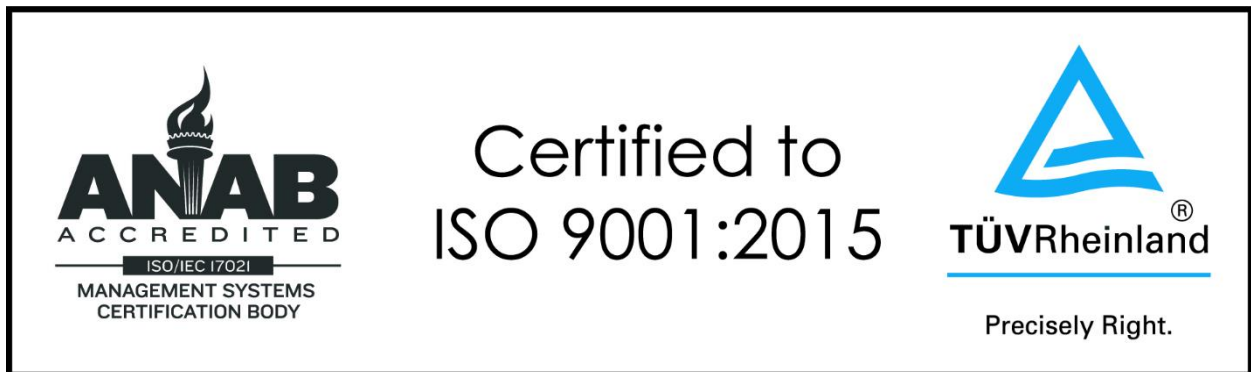



215 West New Road
Greenfield, IN 46140

Toll Free: 800.869.9685

email: info@modernfold.com

www.modernfold.com

A Dormakaba Group Company

www.dormakaba.com

Form No. 8204.2

Revision Date: JANUARY 11, 2021

Manufacturer reserves the right to change design or specifications at any time without notice.