



EURO VISTA SLIDE™

THERMALLY BROKEN LIFT & SLIDE SLIDING DOORS

euro-wall®

www.euro-wall.com
888.989.EURO (3876)



FOLDING



SLIDING

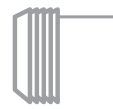

STACKING



PIVOT

SYSTEM THRESHOLDS

Maximum / Minimum Specifications

Max Panel Weight:	500 lbs each panel
Min Panel Width:	24"
Max Panel Width:	96"
Min Panel Height:	32"
Max Panel Height:	166"
Panel Thickness:	1.75"
Max # of Panels:	8

NOTE: When using maximum panel widths & heights, panels may exceed maximum panel weight of 500 lbs. Calculated weight check should be done. For installations in Florida, please see the Florida Product Approval for usage and limitations.

SYSTEM HIGHLIGHTS

Extrusions

Extruded aluminum 6063-T5 with door panel corner keys for strength and security

Hardware

Stainless steel, steel components with corrosion resistant material - salt spray tested 500 hours

Flush or Low Profile Sill

Flush track with finished floor height or 3/8" exposed track - no sill riser required for water rating

Hidden Pockets

Pocket configuration option allows panels to slide into the wall, completely disappearing from view

U Factor

Lowest U factor for any available impact rated lift and slide panel

Track Options

2 track - 5 track options for flexible panel configurations

Matching Fixed Units

To match profile and glass

Largest Impact Rated Panel Sizes

Thermal and non-thermal 13'+ tall panels - the tallest HVHZ impact tested and Florida Product Approved lift and slide panels available

Thermally Broken Option

Impact rated thermally broken panel option - the largest impact tested thermally broken panels available

Aesthetics

Wood cladding option available

Corner Units

90° postless corner units (all impact tested / Florida Product Approved)

Long Lasting Finish

Standard finish coating is AAMA 2605, the highest quality finish available

Under Pressure

Up to 15 lbs of water protection without sill riser

Unhindered View

Highest glass to frame ratio available

SYSTEM COMPONENTS

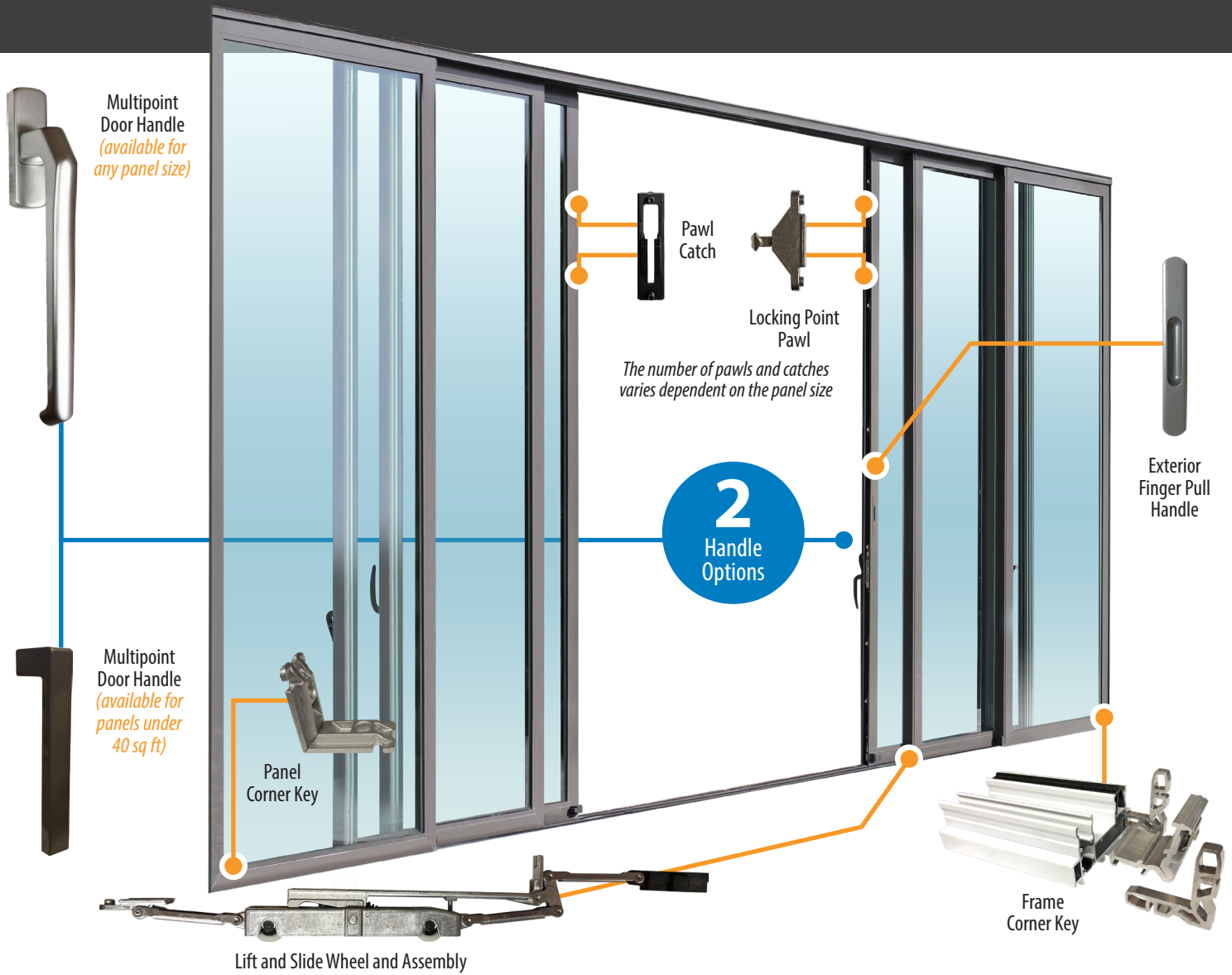

TRACK OPTIONS

The Euro Vista Slide comes in a 2 track, 3 track, 4 track or 5 track configuration.

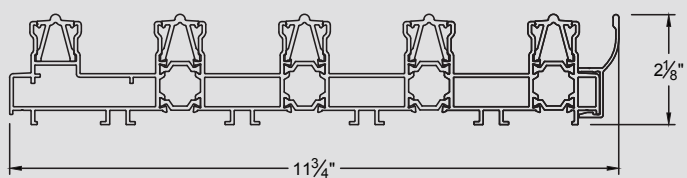
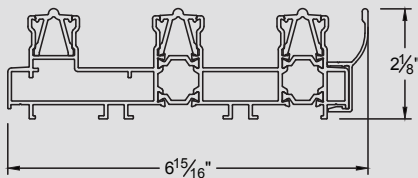
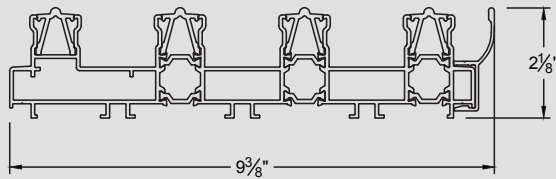
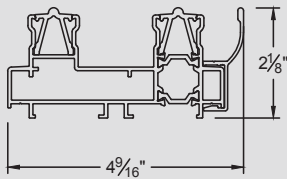

PANEL FINISH OPTIONS

STANDARD FRAME & DOOR PANEL FINISHES

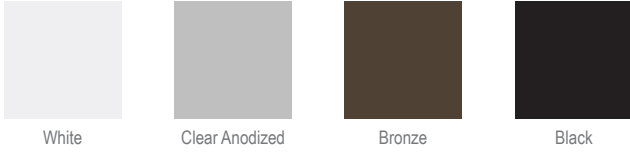

White

Clear Anodized

Bronze

Black

STANDARD FRAME & DOOR PANEL FINISHES

- Powder coat or Kynar® finishes available
- Custom powder coat or Kynar® finishes available
- Manufacturer color match options
- Custom wood grain finishes available

INTERIOR WOOD CLAD FINISH OPTION

- Mahogany / sapele
- White oak
- Additional wood species available



HARDWARE / HANDLE FINISH OPTIONS

MULTIPOINT LOCK HANDLE



AVAILABLE FOR PANELS UNDER 40 SQ. FT

Available Finishes

- Silver
- White
- Bronze
- Black

Custom Colors Available

MULTIPOINT LOCK HANDLE



AVAILABLE FOR ANY PANEL SIZE

Available Finishes

- Brushed Satin
- Bronze
- White

Custom Colors Available

SILL / TRACK

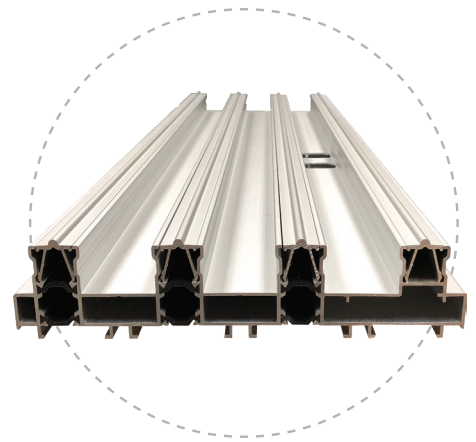

Available Finishes

- Clear Anodized
- White
- Bronze
- Black

Custom Colors Available

GLAZING OPTIONS

Available glass for the Euro Vista Slide are:

- Insulated Glass
- Impact Insulated Glass

SUPERIOR BY DESIGN

CONFIGURATION SAMPLES

O = FIXED PANEL X = ACTIVE PANEL

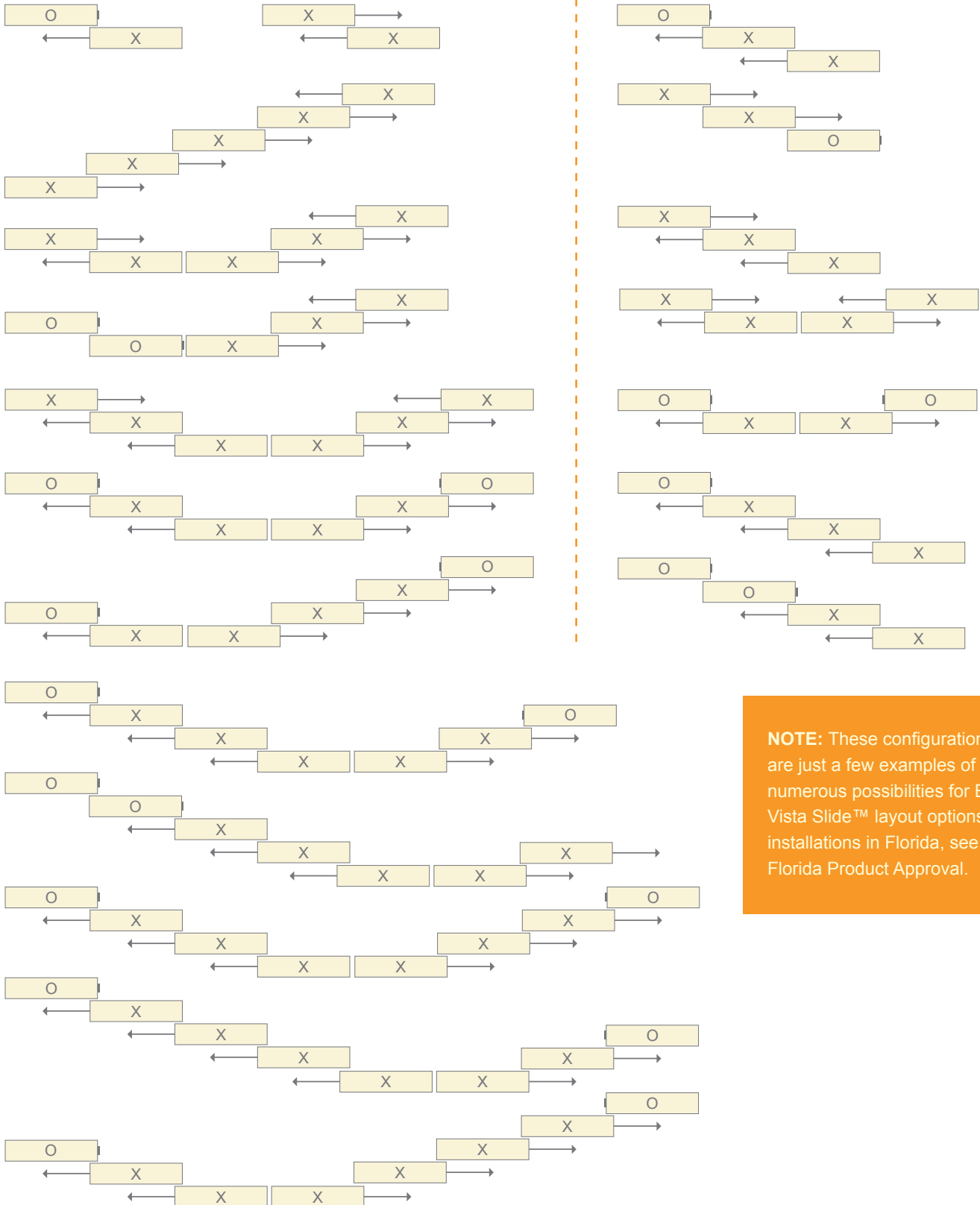

NOTE: These configurations are just a few examples of the numerous possibilities for Euro Vista Slide™ layout options. For installations in Florida, see the Florida Product Approval.

EURO VISTA SLIDE™ SILL PROFILE DETAILS

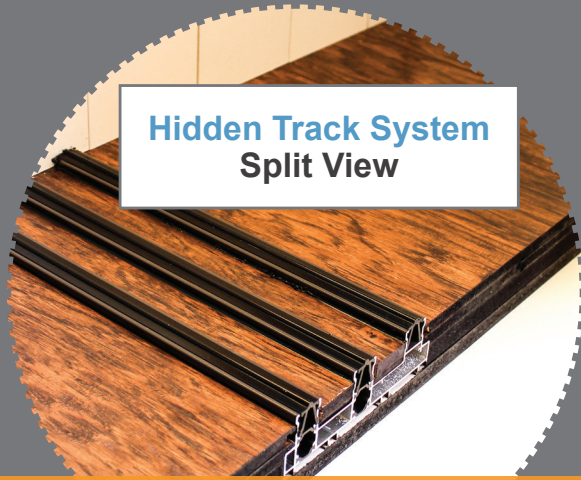

**Hidden Track System
Split View**

NON-THERMALLY BROKEN & THERMALLY BROKEN PANEL OPTIONS

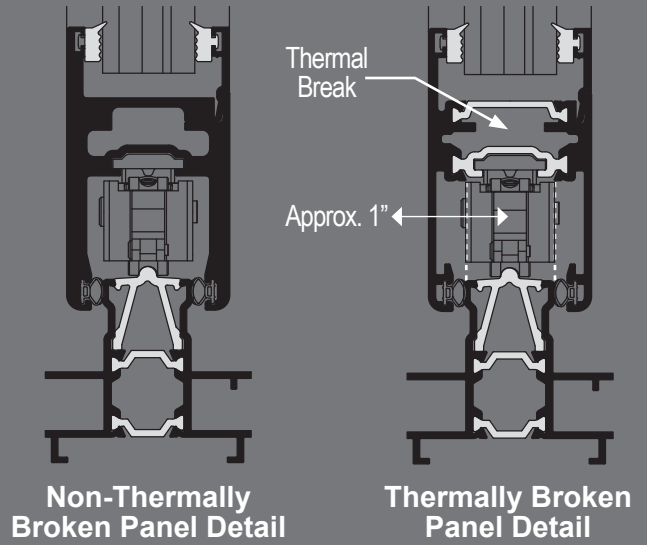

For weather challenged climates, the flush and low profile hidden track systems are manufactured to meet water rating specifications. Additionally, Euro-Wall EXCLUSIVELY manufactures a water rated hidden flush sill.

FLUSH SILL

Hidden Track System
Cross Section

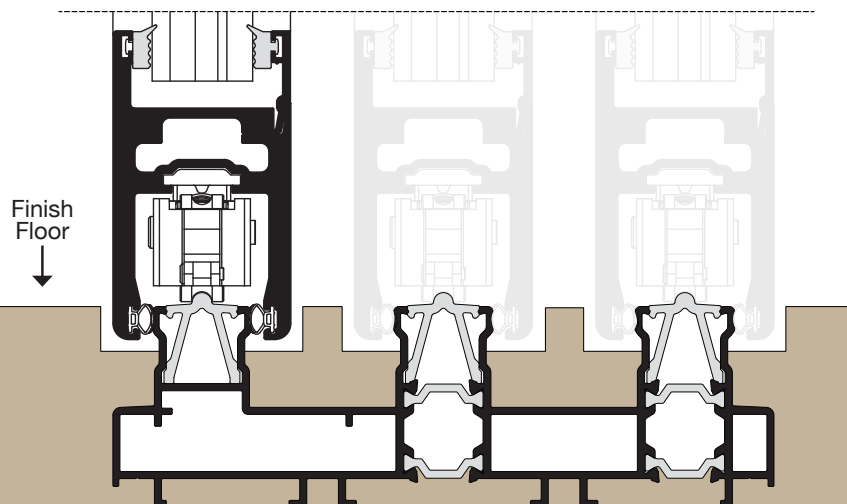

LOW PROFILE SILL

Hidden Track System
Cross Section

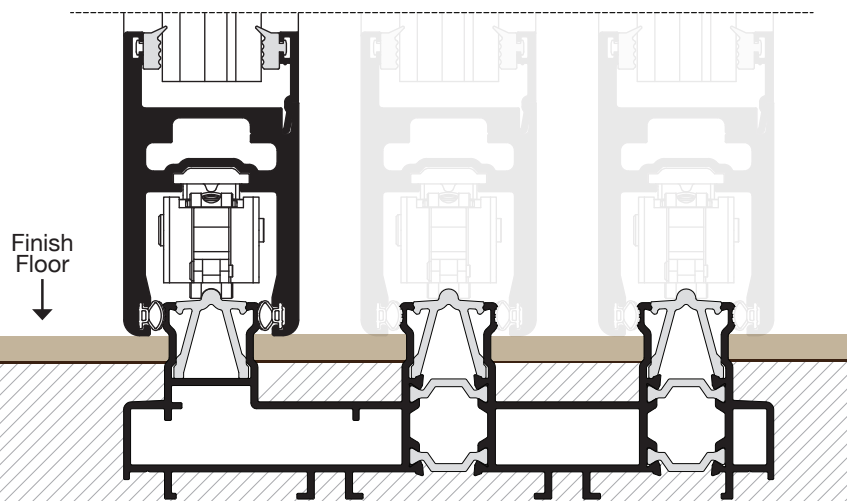
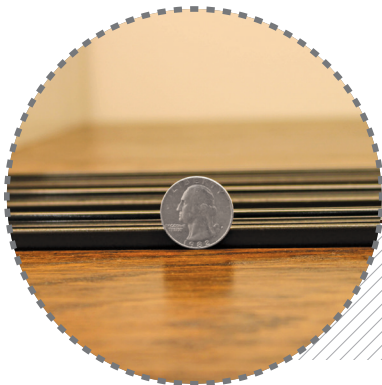



EURO-WALL 10 YEAR WARRANTY

Euro-Wall warrants the products to be free from manufacturing defects for a period of 10 years from the date of purchase.

MANUFACTURING

2200 Murphy Court
North Port, Florida 34289
888.989.3876 • 941.979.5316

888.989.EURO (3876)
www.euro-wall.com

euro-wall®

FOLDING | SLIDING | STACKING | PIVOT

SHOWROOM

1211 Stirling Road, Unit 102,
Dania Beach, Florida 33004
954.610.2572

Proud Member of the American Architectural Manufacturers Association.

